



Bathroom & Restroom Supplies
Product Catalogue



CONTENTS

01	Patents
02-08	New Products
09-18	Model S Series Paper Dispenser
19	Model S Series Aerosol Dispenser
20	Model S Series Sanitizer Dispenser
21-22	Model S Series Soap Dispenser
23-28	Automatic Soap Dispenser
29-31	Manual Soap Dispenser
32	Manual Tubing Soap Dispenser
33-40	Hand/Surface Cleaner Dispenser
41-44	Fan Dispenser
45-50	Toilet/Urinal Sanitizer Dispenser
51-52	1100 Series of Aerosol Dispenser
53	2100 Series of Aerosol Dispenser
54	3100 Series of Aerosol Dispenser
55	Action Head Series of Aerosol Dispenser
56	Interchangeable Aerosol Action Heads
57	1500 Series of Aerosol Dispenser
58	D Size Battery Series of Aerosol Dispenser
59-60	Mini Aerosol Dispenser
61	Retail Aerosol Dispenser
62	Solenoid Valve Aerosol Dispenser
63-66	Pump Dispenser
67-69	Big Space Fragrance Diffuser
70-71	Air Freshener
72	Skin Care Product
73	Sanitary Bin
74-77	Accessories

2024 NEW PRODUCTS

INNOVATION HIGHLIGHTS

INNOVATION PRODUCT Auto Assist Paper Towel Dispenser

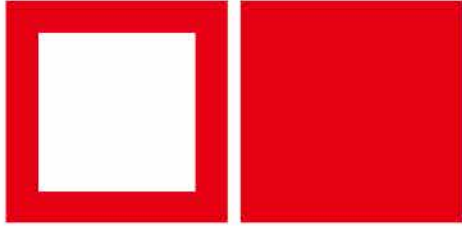

Jam-Free

Auto Assist Paper Towel Dispenser

P870A

- Dual Functionality. Offers both Manual and Sensor modes in a single device
- Automatic next sheet feeding by 60mm after pulling, under both modes
- Battery Saving. Special blade angle designed for easy paper cutting
- LED Paper remaining warning indicator
- LED Low battery warning indicator
- Operates with 4xC (LR14) alkaline batteries, 3.7V lithium batteries, or 6V DC adaptor
- Roll support options: 35mm, 45mm. Other core sizes, coreless support are made upon request

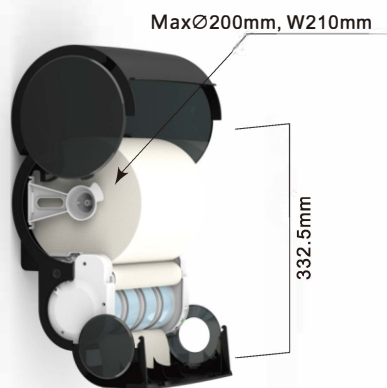

Vacant Design

2024 NEW PRODUCTS

INNOVATION HIGHLIGHTS

INNOVATION PRODUCT Auto Assist Paper Towel Dispenser



Ultra Compact Sensor Tear-off Paper Towel Dispenser

P860T

- Ultra Space Saving design. Innovative compact solution for regular size rolls
- Adjustable sheet length setting. Default setting length: Min / Med / Max
- Battery saving using Infrared technology
- LED Low battery warning indicator
- Operates with 4xC (LR14) alkaline batteries, or 6V DC adaptor
- Roll support options: 35mm, 45mm. Other core sizes, coreless support are made upon request

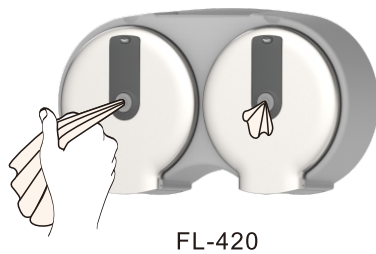
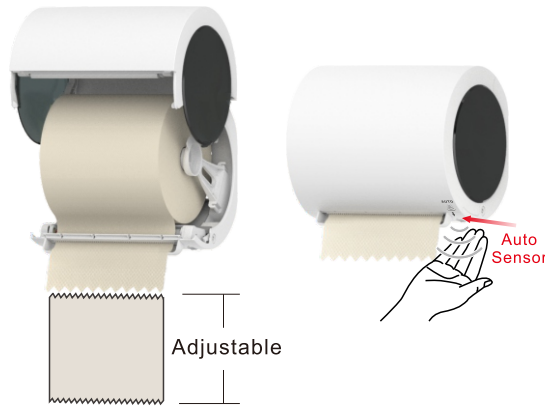
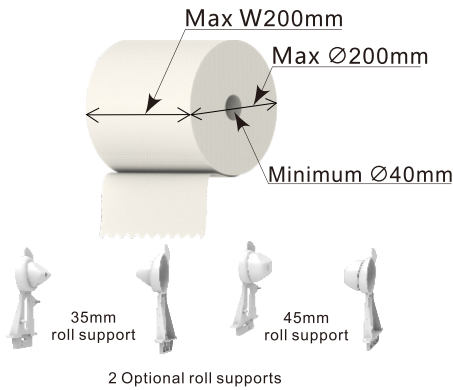

FL-420

Stainless steel Dual Jumbo Roll Toilet Tissue Dispenser

- For use with toilet tissue rolls (Max Diameter 240mm and Min Width 100mm)
- Dual Opening. Two covers open separately for easy loading
- Stainless steel material cover
- Eco friendly recyclable ABS material
- Supported by Hygienekey APP

RL-420 FL-420

- Patented Anti-Fall Serration Holder Design to support tissue
- Front opening and center pulling for easy tissue feeding and maintenance

RL-430 FL-430

- Interchangeable core options: 50mm/ 60mm/ 73.5mm/ 35mm coreless support. Other core sizes are made upon request

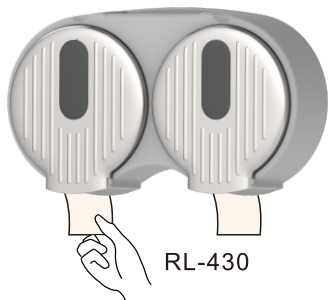

RL-430

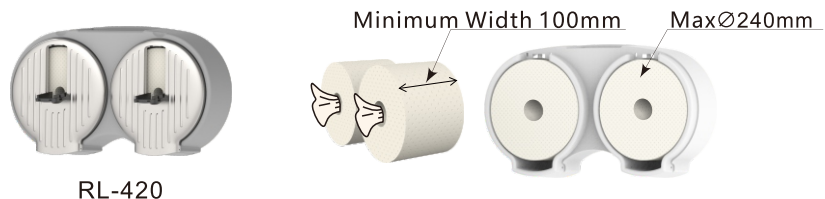
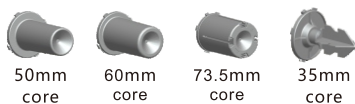

RL-420

2023 NEW PRODUCTS

INNOVATION HIGHLIGHTS

PATENT PRODUCT Enriched Foam Dispensing Module

A new way to dispense foam soap in cost-efficient and technically reliable way.

FEATURES:

- No traditional foam pump needed
- A mini air compressor to replace motor and gear system
- Dose size can be adjusted, default setting at 0.6ml
- High air/liquid ratio provides excellent foaming performance
- Bottle customizable for different volume and shape

BENEFITS:

- No pump replacement required; Less cost
- Simple operation and maintenance
- 4 pcs AA batteries (LR6) last 20 liters of soap, or 50,000 times of action



PATENT PRODUCT AH-76Neo



VL-710A



UL-710A



SL-710A



7810A



Soap Bottle



4 Pcs AA Battery



Waterproof Cap



PCB



PCB Tray

Automatic Foam Dispenser

AH-76Neo

- Innovation foam dispensing module with PATENT
- Waterproof level: IPX4
- 4 Optional dispenser designs, VL-710A, UL-710A, SL-710A and 7810A
- Working with 4pcs AA alkaline batteries (LR6). Able to last 20,000ml soap or 50,000 times of action
- Adjustable dose size
- Available for 1200ml refillable bottle

2023 NEW PRODUCTS

INNOVATION HIGHLIGHTS

PATENT PRODUCT Automatic Counter-mount Foam Dispenser

Automatic Counter-mount Foam Dispenser

- Innovated Patented dispensing module.
Rich foam performance
- Top Opening with Silicone Funnel. Mess-free refilling from the top
- Adjustable dosage. Default options: 0.4/0.6/1.0ml Max 2.0ml
- Available refill options: 1500ml refillable bottle/ disposable pouch/other customization upon request
- 304 Stainless steel material
- Operates with 4xAA (LR6), 4xD (LR20) alkaline batteries, or 5V DC adaptor



PATENT PRODUCT Automatic Foam Dispenser Stand

Automatic Foam Dispenser Stand 7430A

- Innovation foam dispensing module with PATENT
- Dispenser on Stand design
- Working with 4pcs AA alkaline batteries (LR6)
- Adjustable dose size
- Available for 600ml refillable bottle

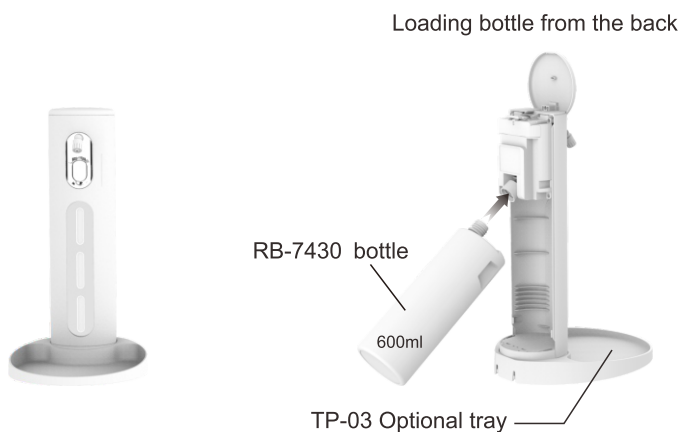
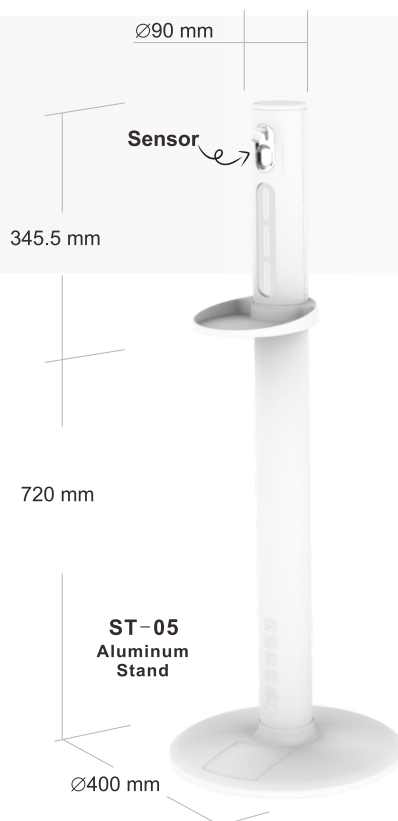

2023 NEW PUMP INNOVATION HIGHLIGHTS

Upside Down Foam Pump Made Specially For Dispenser Use

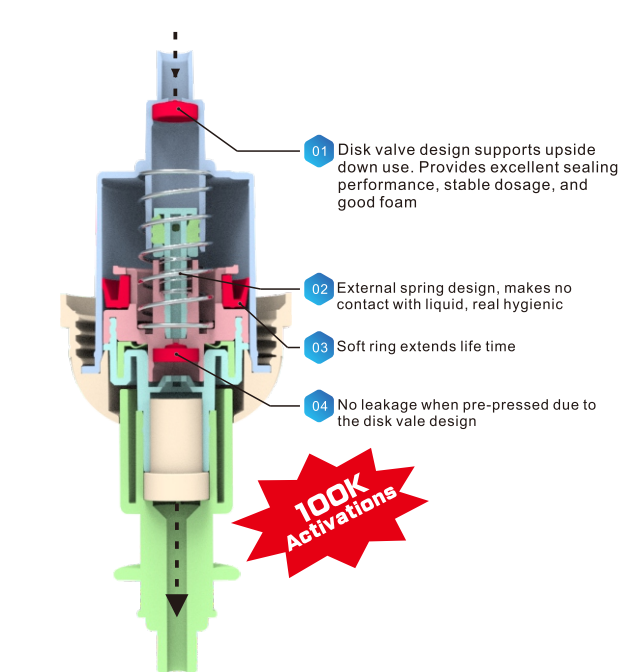

Faner New Pump
Design For Dispenser Use

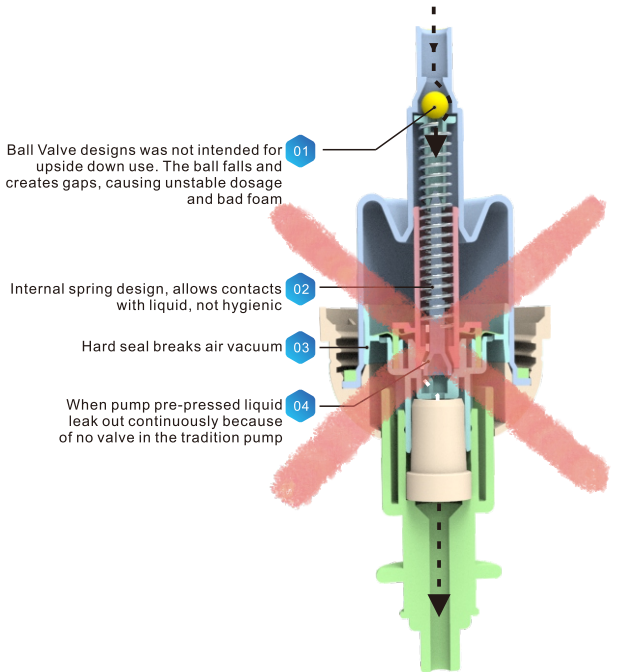

Traditional Pump
Not Intended For Dispenser Use

Upside Down Soap Pump Made Specially For Dispenser Use

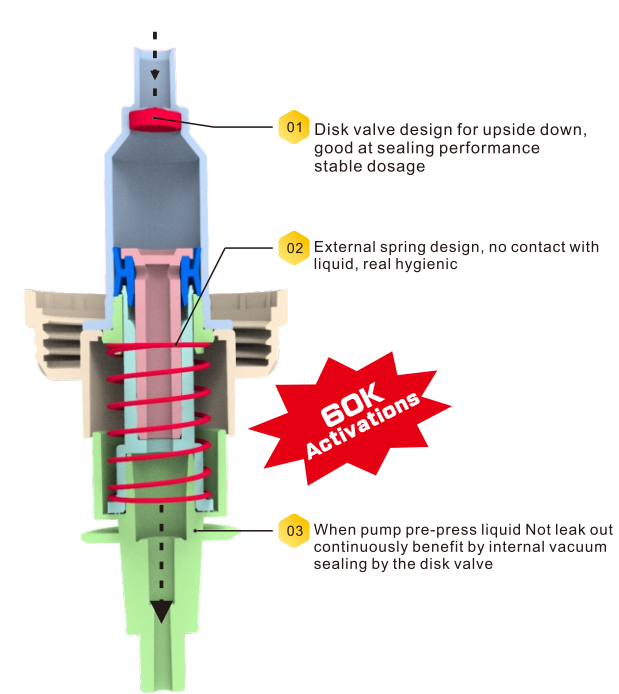

Faner New Pump
Design For Dispenser Use

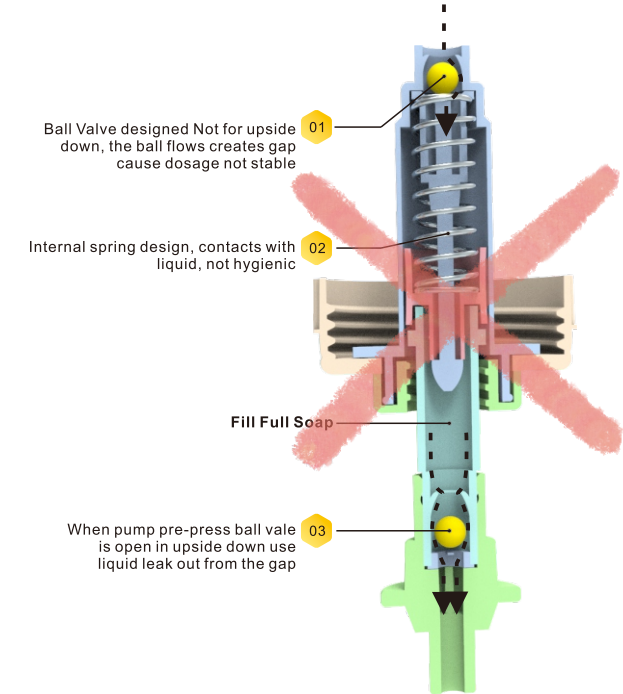

Traditional Pump
Not Intended For Dispenser Use

2023 NEW PRODUCTS

INNOVATION HIGHLIGHTS

INNOVATION PRODUCT Paper Towel Dispenser

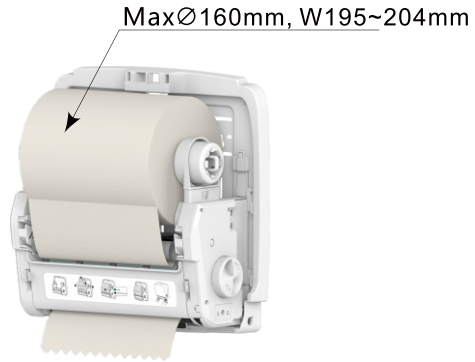

Jam-Free

Super Compact Paper Towel Dispenser

SL-850A

- Dual use, available for both Touch free and Manual use
- Automatically feeds a 60mm sheet after pulling, under both Touch free and Manual use versions
- Power saving, special angle blade to cut paper easily
- Auto cutting, each sheet is 230mm economic length
- LED Paper remaining warning indicator
- LED Low battery warning indicator
- Supported by Hygienekey APP
- Operates with 4xAA (LR6) lasting up to 17 rolls, or 6V DC adaptor
- Roll support options: 35mm and 45mm. Other core sizes, coreless support are made upon request

Automatic



Manual



Sensor

New angle blade, cutting paper easily!

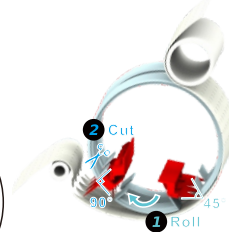

60mm

When battery runs out, switch to manual.

Second sheet of 60mm comes out automatically!

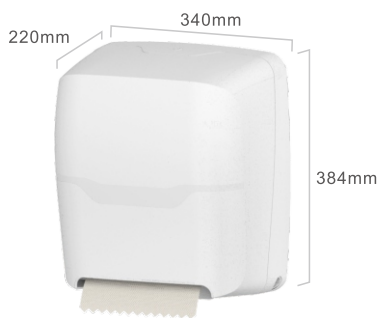

810 & 820



850

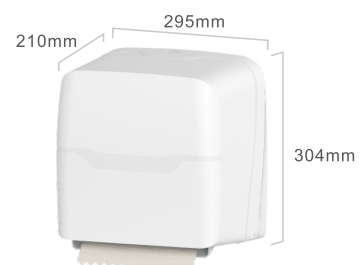

860

2023 NEW PRODUCTS

INNOVATION HIGHLIGHTS

PATENT PRODUCT AH-76NX Waterproof level: IPX6

AH-76NX

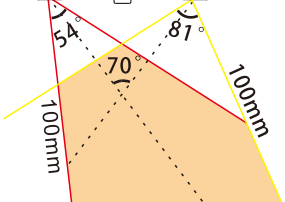
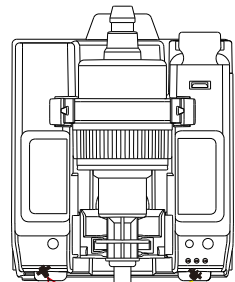
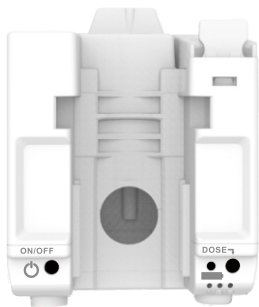

Sensing area
V-type infrared emission
to prevent interference

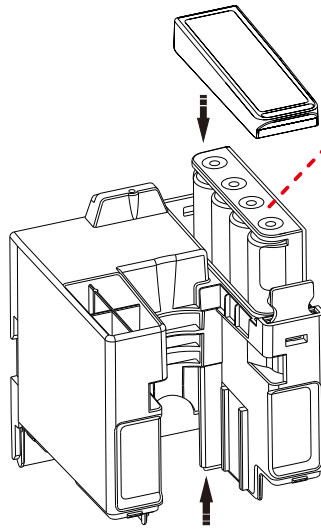

Using battery case

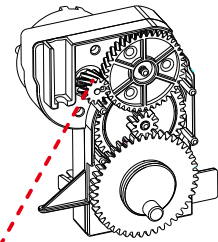
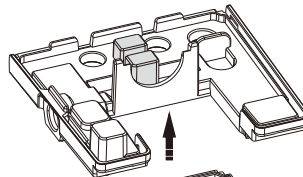

Helical gear design
high torque force
& noiseless system

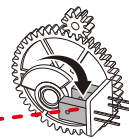
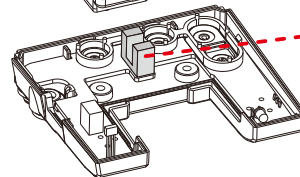

Infrared sensor
Reliable and durable,
optical infrared sensor
(World Wide Patent)

INNOVATION PRODUCT Air Freshener

3 in 1 Air Freshener

- Up to 3 aroma scents in 1 freshener dispenser.
- Optional working time and separated working function
- Available for single unit use



Wooden Wick Air Freshener



Available for DC power
OUTPUT:6V = 5A

INNOVATION PRODUCT Urinal Screen

Urinal Screen

- Environmental friendly material PET, attaching on nonwoven screen
- Recyclable material
- Carved date for indicating refill remaining time
- Color changing with temperature change
- Optional aroma scents
- Fully automated production line

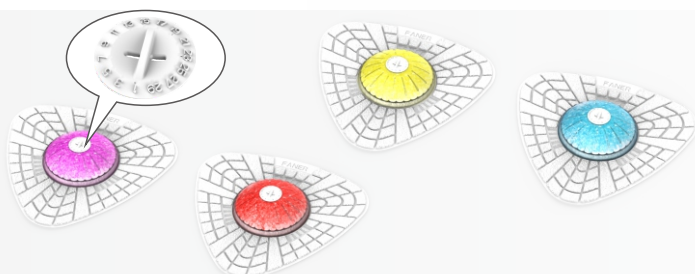

MODEL S SERIES



Model S Series-Paper Dispenser

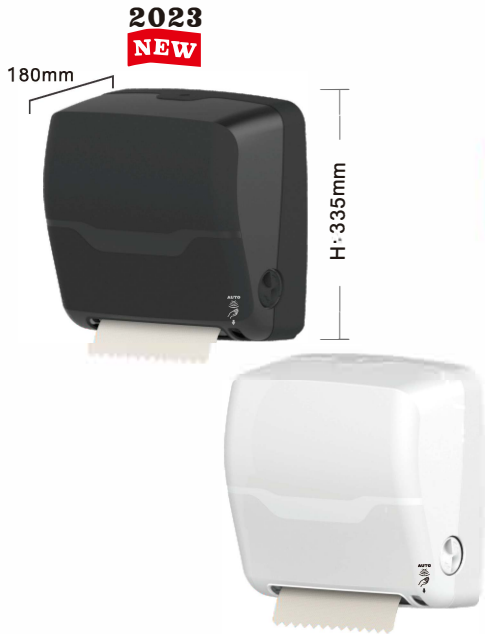

Jam-Free

Super Compact Sensor Paper Towel Dispenser

SL-850A

- Dual use, available for both Touch free and Manual use
- Automatically feeds a 60mm sheet after pulling, under both Touch free and Manual use versions
- Power saving, special angle blade to cut paper easily
- Auto cutting, each sheet is 230mm economic length
- LED Paper remaining warning indicator
- LED Low battery warning indicator
- Supported by Hygienekey APP
- Operates with 4xAA (LR6) lasting up to 17 rolls, or 6V DC adaptor
- Roll support options: 35mm and 45mm. Other core sizes, coreless support are made upon request

Material	Dimension	Packaging	Carton Size	G.W/kg
PP	340*180*335	1PCS/CTN	350*195*345	2.4



Each Sheet Is 23cm Only , Paper Saving !



2 Optional roll supports



Available for DC power
OUTPUT:6V=2A

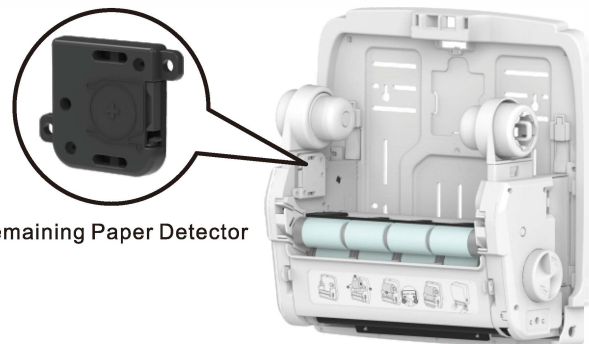

Remaining Paper Detector



Auto Sensor



Second sheet of 60mm comes out automatically!

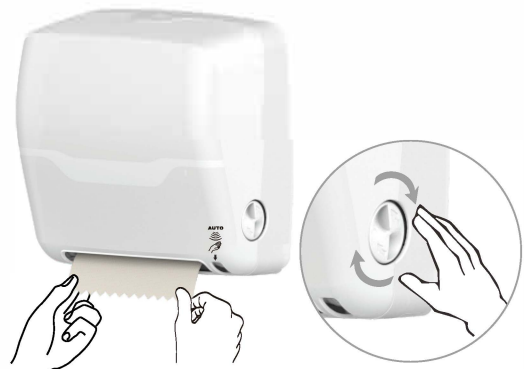

When battery run out, twist knob for next sheet and seamlessly switch to manual mode.

Model S Series-Paper Dispenser



Jam-Free

Super Compact AutoCut Paper Towel Dispenser

SL-850MP/SL-850MR

- Manual, pulling to cut paper easily
- Optional Push bar or Twist knob to feed paper
- Each sheet in 230mm economic length
- Supported by Hygienekey APP
- Roll support options: 35mm and 45mm. Other core sizes, coreless support are made upon request

Material	Dimension	Packaging	Carton Size	G.W/kg
PP	340*180*335	1PCS/CTN	350*195*345	2.1



2 Optional roll supports

MaxØ170mm, W195~200mm

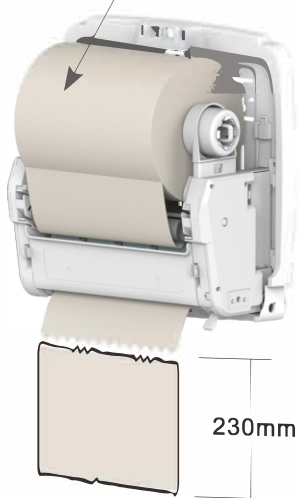

Each Sheet Is 23cm Only ,
Paper Saving !

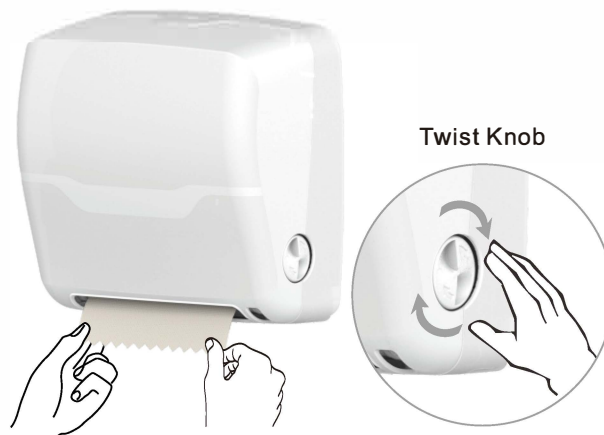
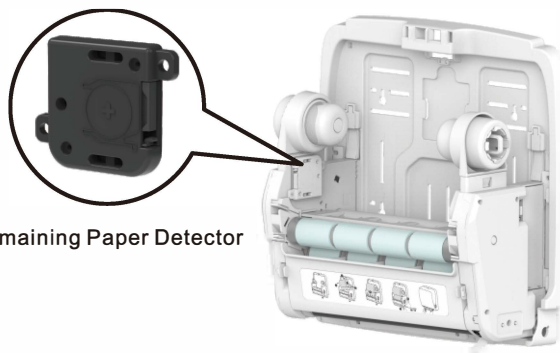

Model S Series-Paper Dispenser

2023
NEW



H:359mm



Jam-Free

Sensor Tear Off Jumbo Roll Tissue Dispenser

266

- Bladeless design, ensures safety, stability and no paper jam
- Infrared sensor. Wave to activate
- Adjustable sheet length. Automatic paper feeding and retrieving
- Paper pinched for controlled output and easy pulling
- LED Low battery warning indicator
- Supported by Hygienekey APP
- Operates with 6xAA (LR6) alkaline batteries, or 8.4V DC Power
- Roll support options: 50mm, 73.5mm. Other core sizes, coreless support are made upon request



Material	Dimension	Packaging	Carton Size	G.W/kg
ABS	289*166*359	4PCS/CTN	590*375*360	5.6



50mm
Core



73.5mm
Core



Available for DC power
OUTPUT:8.4V==4.5A

MaxØ230mm, W90~100mm



2023
NEW

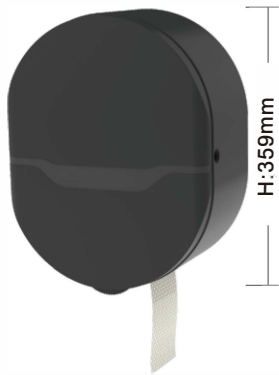

H:359mm



Jam-Free

Battery Free Autocut Jumbo Roll Tissue Dispenser

SL-240

- Battery free, easy pull and cut tissue
- Automatically feeds a second sheet after pulling
- Each sheet length is 300mm
- Supported by Hygienekey APP
- Special structure design of 150mm small roller blade
- Interchangeable core options: 50mm/ 60mm/ 73.5mm/ 35mm coreless support. Other core sizes are made upon request



Material	Dimension	Packaging	Carton Size	G.W/kg
ABS	289*166*359	4PCS/CTN	590*375*360	5.6



50mm
Core



60mm
Core



73.5mm
Core



35mm
Coreless Spike

MaxØ230mm, W90~100mm



Model S Series-Paper Dispenser



Super Compact Sensor Paper Towel Dispenser

SL-860

- Compact design. Innovative compact solution for regular size rolls
- Touch free sensor. Wave to dispense
- Adjustable sheet length setting: 5 options
- Eco friendly recyclable PP material
- LED Paper remaining warning indicator
- LED Low battery warning indicator
- Supported by Hygienekey APP
- Operates with 4xD (Lr20), 6xC (LR14) alkaline batteries, or 6V DC adaptor
- Roll support options: 35mm, 45mm. Other core sizes, coreless support are made upon request

Material	Dimension	Packaging	Carton Size	G.W/kg
PP	295*210*304	1PCS/CTN	315*230*320	2.5

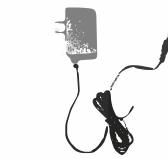

Available for DC power
OUTPUT:6V=5A

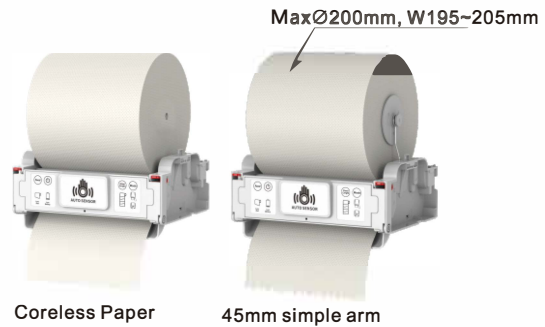

Sensor Paper Towel Dispenser

SL-820A: Sensor Autocut

SL-820B: Sensor Tear off

- Touch free sensor. Wave to dispense
- Adjustable sheet length setting: 5 options
- Eco friendly recyclable PP material
- LED Paper remaining warning indicator
- LED Low battery warning indicator
- Supported by Hygienekey APP
- Operates with 4xD (Lr20), 6xC (LR14) alkaline batteries, or 6V DC adaptor
- Roll support options: 35mm, 45mm, 38mm coreless support. Other core sizes are made upon request

Material	Dimension	Packaging	Carton Size	G.W/kg
PP	340*220*384	1PCS/CTN	396*353*237	4

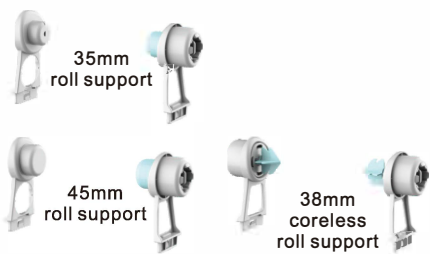

Available for DC power
OUTPUT:6V=5A

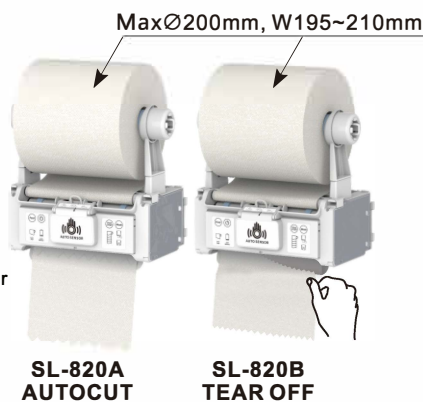

Patent

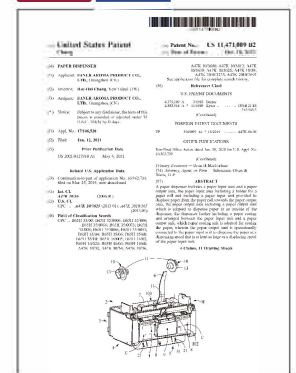

Model S Series-Paper Dispenser



Battery Free Autocut Paper Towel Dispenser

SL-810

BENEFITS:

- Easy-pull design allows pulling from any angle
- The next sheet comes out automatically; no need for another push
- Jam-free

FEATURES:

- Automatic next sheet feeding by 60mm after pulling
- Special blade angle designed for easy paper cutting
- Eco friendly recyclable PP material
- LED Paper remaining warning indicator
- Supported by Hygienekey APP
- Roll support options: 35mm, 45mm, and 38mm coreless support. Other core sizes are made upon request



Material	Dimension	Packaging	Carton Size	G.W/kg
PP	340*220*384	1PCS/CTN	396*353*237	3.8

Patent

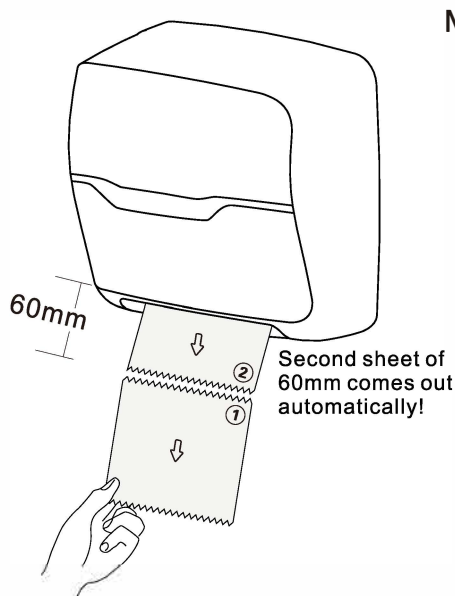

MaxØ200mm, W195~210mm



Battery free

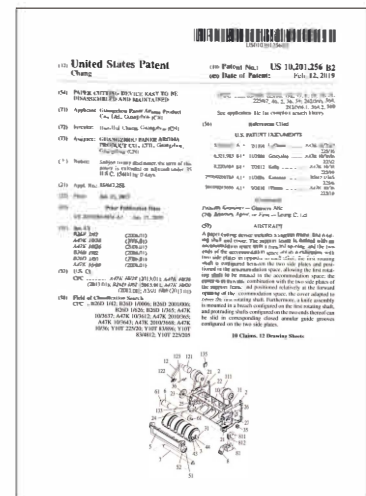

3 Optional roll supports
Innovative Retractable Core for Easy Loading Towel Roll

Model S Series-Paper Dispenser



H: 366mm

Maxi



Maxi Centerpull Paper Towel Dispenser

SL-110

- For use with maxi center feed paper towel (Max Diameter 200mm)
- The cover opens downward for easy refilling
- Eco friendly recyclable PP material
- Supported by Hygienekey APP
- Optional adjustable funnel available (for tightness control)



Material	Dimension	Packaging	Carton Size	G.W/kg
PP	235*216*366	1PCS/CTN	238*220*368	1.64

Ø:200mm



MaxØ200mm
Max W240mm



Adjustable funnel ensures one sheet per pulling



H: 324.5mm

Mini



Mini Centerpull Paper Towel Dispenser

SL-120

- For use with mini center feed paper towel (Max Diameter 140mm)
- The cover opens downward for easy refilling
- Eco friendly recyclable PP material
- Supported by Hygienekey APP
- Optional adjustable funnel available (for tightness control)



Material	Dimension	Packaging	Carton Size	G.W/kg
PP	176*155*324.5	1PCS/CTN	180*162*328	1.08

Ø:140mm



MaxØ140mm
Max W210mm



Adjustable funnel ensures one sheet per pulling

Model S Series-Paper Dispenser

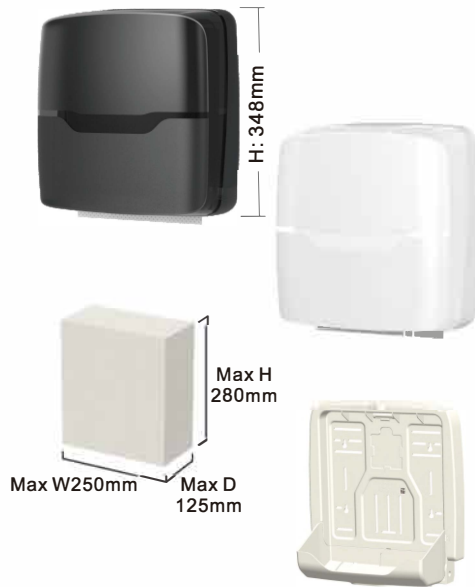

V Folded Paper Towel Dispenser

SL-310

- For use with V-folded paper towel. Fits 2.5 stacks of standard size towel packs
- The cover opens downward for easy refilling
- Eco friendly recyclable PP material
- Supported by Hygienekey APP



Material	Dimension	Packaging	Carton Size	G.W/kg
PP	324*160*348	1PCS/CTN	335*165*365	1.67

Z Folded Paper Towel Dispenser

SL-320

- For use with Z-folded paper towel. Fits 2.5 stacks of standard size towel packs
- The cover opens downward for easy refilling
- Eco friendly recyclable PP material
- Supported by Hygienekey APP

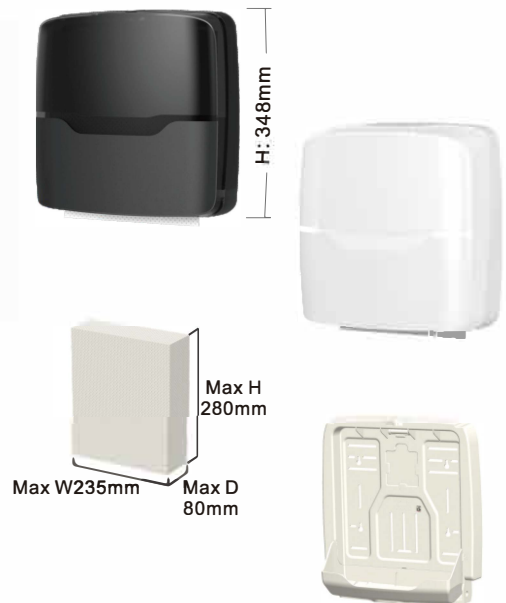

Material	Dimension	Packaging	Carton Size	G.W/kg
PP	324*109.5*348	1PCS/CTN	335*110*365	1.51

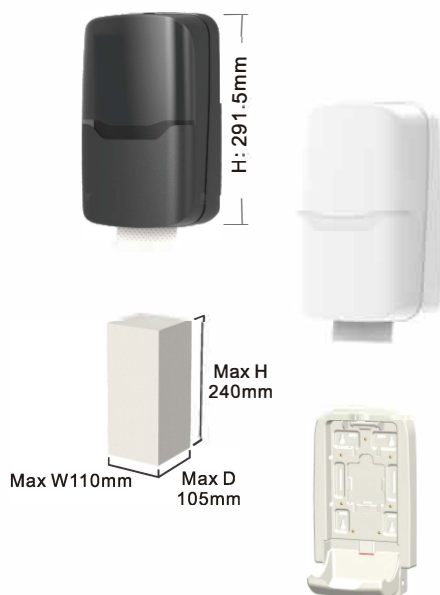

Interfold Toilet Tissue Dispenser

SL-330

- For use with Z-folded tissue towel. Fits 2.5 stacks of standard size tissue packs
- The cover opens downward for easy refilling
- Eco friendly recyclable PP material
- Supported by Hygienekey APP



Material	Dimension	Packaging	Carton Size	G.W/kg
PP	168*124*291.5	6PCS/CTN	450*375*323	5

Model S Series-Paper Dispenser



SL-230 Maxi

H: 338mm



SL-210 Mini

H: 277mm

Jumbo Roll Toilet Tissue Dispenser

SL-210 and SL-230

- The cover opens downward for easy refilling
- Eco friendly recyclable PP material
- Supported by Hygienekey APP
- Interchangeable core options: 50mm/ 60mm/ 73.5mm/ 35mm coreless support. Other core sizes are made upon request



Remaining Paper Detector

SL-230 Maxi

Material	Dimension	Packaging	Carton Size	G.W/kg
PP	332*137*338	1PCS/CTN	340*145*345	1.5

SL-210 Mini

Material	Dimension	Packaging	Carton Size	G.W/kg
PP	258*121*277	1PCS/CTN	265*130*283	1.07

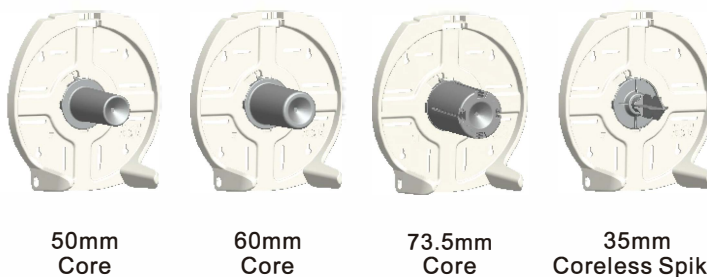
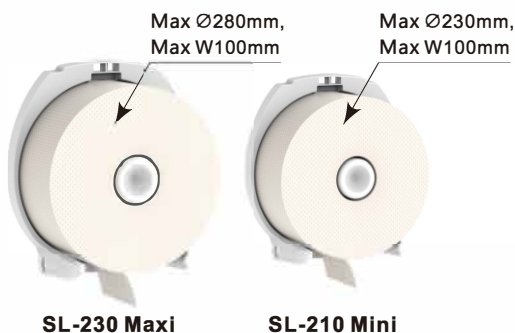

H: 291.5mm



Mini Dual Roll Toilet Tissue Dispenser

SL-410

- For use with toilet tissue rolls (Max Diameter 135mm and Max Width 96mm)
- Dual roll paper holder: One roll in use while the other as back up
- The cover opens downward for easy refilling
- Eco friendly recyclable PP material
- Supported by Hygienekey APP
- Roll support option: Coreless spike



Remaining Paper Detector

Material	Dimension	Packaging	Carton Size	G.W/kg
PP	308*124*195	6PCS/CTN	447*442*337	6.1

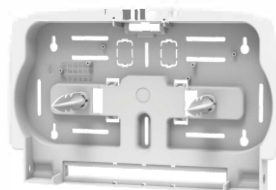
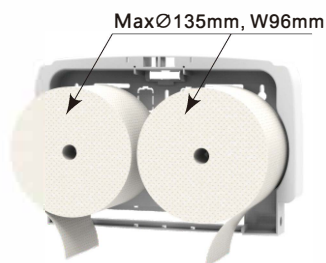

18mm Coreless Spike

Model S Series-Paper Dispenser



Front Centerpull Jumbo Roll Toilet Tissue Dispenser

SL-220

- For use with toilet tissue rolls (Max Diameter 240mm and Min Width 100mm)
- Front window opens easily for towel feeding and maintenance
- Eco friendly recyclable PP material
- Supported by Hygienekey APP



Material	Dimension	Packaging	Carton Size	G.W/kg
PP	275*138*280	1PCS/CTN	290*150*295	1.5



Front Centerpull Dual Jumbo Roll Toilet Tissue Dispenser

SL-420

- For use with toilet tissue rolls (Max Diameter 135mm and Max Width 96mm)
- Front windows open separately for easy towel feeding and trouble shooting
- Eco friendly recyclable PP material
- Supported by Hygienekey APP



Material	Dimension	Packaging	Carton Size	G.W/kg
PP	312*136*182	6PCS/CTN	340*385*430	7.2



Model S Series Aerosol Dispenser



Aerosol Dispenser

SL-510

- Long lasting battery life: more than 12 refills
- For use with 270ml aerosol refill cans
- The cover opens upward for easy refilling
- Interchangeable action heads for function requirements
- Eco friendly recyclable PP material
- Supported by Hygienekey APP
- Operates with 2xAA alkaline batteries (LR6)

Material	Dimension	Packaging	Carton Size	G.W/kg
PP	88*87.5*224	30PCS/CTN	510*286*505	13.65



LCD

LED



MODEL:AH-11



MODEL:AH-12



MODEL:AH-21



MODEL:AH-22BT



MODEL:AH-16



MODEL:AH-17



MODEL:AH-22

Optional Action Heads



SL-520LCD

SL-520LED

Mini Aerosol Dispenser

SL-520

- Long lasting battery life: more than 12 refills
- For use with 110ml aerosol refill cans
- The cover opens upward for easy refilling
- Interchangeable action heads for function requirements
- Eco friendly recyclable PP material
- Supported by Hygienekey APP
- Operates with 2xAA alkaline batteries (LR6)

Material	Dimension	Packaging	Carton Size	G.W/kg
PP	83*63*186	30PCS/CTN	490*240*410	11



MODEL: SL-520LCD AH-10



MODEL: SL-520LED AH-20

Model S Series Sanitizer Dispenser



H: 188mm



Urinal Sanitizer Dispenser

SL-610

- Refill capacity is 400ml and pump dosage is 0.12ml
- Screw pump and crimping pump are both available
- Three versions available: programmable LCD, economy LED, Hygienekey version
- The cover opens downward for easy refilling
- Eco friendly recyclable PP material
- Supported by Hygienekey APP
- Operates with 2xC alkaline batteries (LR14)

Material	Dimension	Packaging	Carton Size	G.W/kg
PP	138*73*188	12PCS/CTN	450*335*230	6.4

SL-610BT



Hygienekey

SL-610LCD

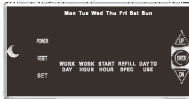

SL-610LED

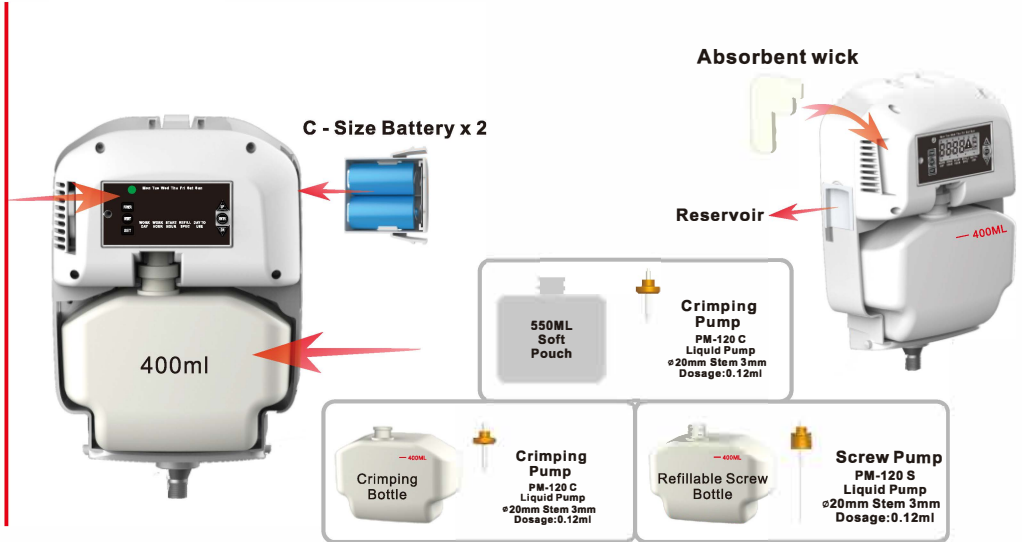

H: 226mm



Dual use Urinal Sanitizer Dispenser

SL-620

- Refill capacity up to 120ml and 360ml, with 0.12ml dosage
- Dual use including aroma and sanitizer dispensing
- Three working modes, dispensing aroma, sanitizer or both at the same time
- Waterproof design to support special environment
- The cover opens downward for easy refilling
- Eco friendly recyclable PP material
- Supported by Hygienekey APP
- Operates with 4xC alkaline batteries (LR14)

Material	Dimension	Packaging	Carton Size	G.W/kg
PP	142*85*226	12PCS/CTN	450*335*230	6.4

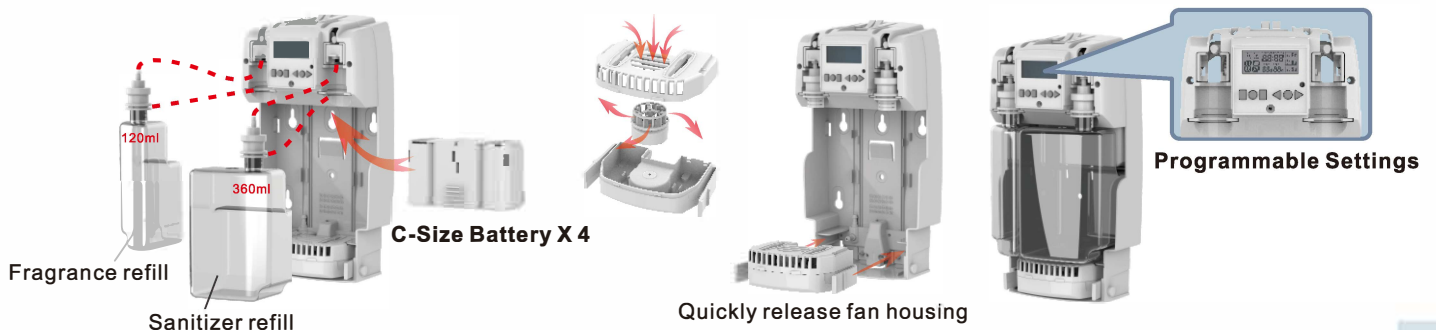

Model S Series-Soap Dispenser



Automatic Soap Dispenser

SL-710A-AH76N

- Waterproof level: IPX4
- Innovative product of helical gear system. Higher force with less noise
- Supported by Hygienekey APP
- Operates with 4xAA alkaline batteries (LR6)
- Compatible with 1100ml refillable bottle or 800ml disposable pouch
- Compatible with foam, lotion, and spray pump

Material	Dimension	Packaging	Carton Size	G.W/kg
PP	140*114*257	12PCS/CTN	420*425*280	9.3



2 Optional Cartridges



AH-76N
AA-Size Battery x 4
5V DC power supply

2023
NEW



AH-76NX
AA-Size Battery x 4
5V DC power supply

Available for 0.6ml durable pump



Available for DC power
OUTPUT:5V=1A

FPK-01



0.4ml

2022
NEW

FPK-04N



0.4ml

Durable

2022
NEW

FPK-15



0.6ml

Durable

LPK-12



1.0ml

2022
NEW

LPK-15



0.6ml

Durable

SPK-12



1.0ml



Manual Soap Dispenser

SL-710M

- Special design push bar
- Compatible with 1200ml refill bottle or 1000ml disposable pouch
- Compatible with foam, lotion, and spray pump

Material	Dimension	Packaging	Carton Size	G.W/kg
PP	140*126*257	12PCS/CTN	570*460*285	7.5



2 Optional Cartridges

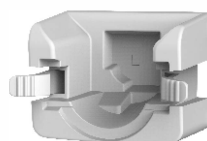

AH-78M

2022
NEW

FPK-16



0.6ml

Durable

FPK-30



0.4ml

2022
NEW

FPK-30N



0.4ml

Durable

FPK-43



0.75ml

LPK-14



1.0ml

SPK-14



1.0ml

Model S Series-Soap Dispenser



Manual Hand/Surface Cleaner Dispenser

SL-720M

- Special design push bar
- Compatible with 600ml refill bottle or 500ml disposable pouch
- Compatible with foam, lotion, and spray pump

Material	Dimension	Packaging	Carton Size	G.W/kg
PP	93*108*204	12PCS/CTN	420*335*225	5.6



500ml Soft Pouch



600ml HDPE Bottle

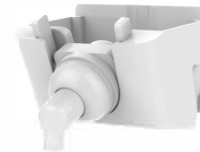

AH-720MX

2022 NEW

FPK-02



0.4ml



Durable

0.4ml

FPK-05



1.0ml

LPK-13



1.0ml

SPK-13



500ml Soft Pouch



600ml HDPE Bottle

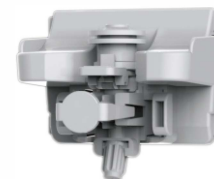

AH-720MS

SPK-03B



0.2ml

SPK-06C



0.5ml

SPK-06



1ml

SPK-06N

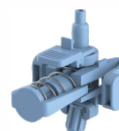

1ml

SPK-07



1ml

SPK-07B



1ml

SOAP DISPENSER

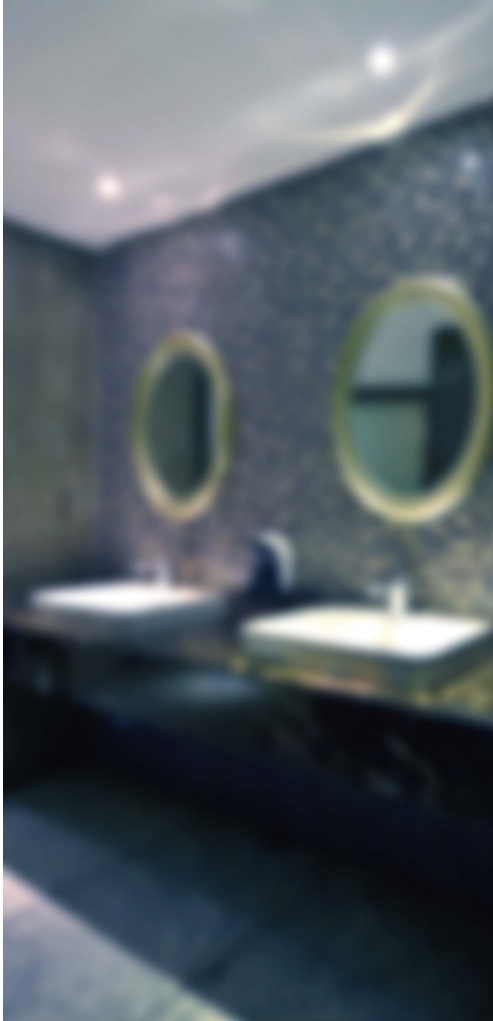

Patent



Air Compressor Foam Soap Mechanism

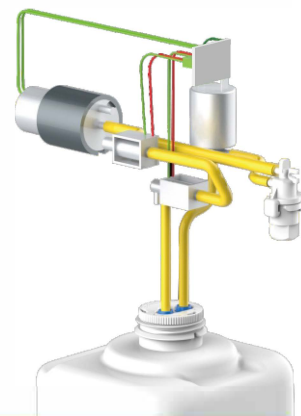

Automatic Soap Dispenser

Pumpless Automatic Foam Soap Dispenser

7900

- Patented air compressor design. No disposable pump required. Cost saving and eco-friendly
- Touch less sensor
- Adjustable dosage
- Supported by Hygienekey APP
- Operates with 4xC alkaline batteries (LR14)
- Compatible with refillable bottles larger than 1000ml (customizable bottle size). Default bottle size is 1000ml



Material	Dimension	Packaging	Carton Size	G.W/kg
PP	148*139*239.5	6PCS/CTN	310*430*250	6.5

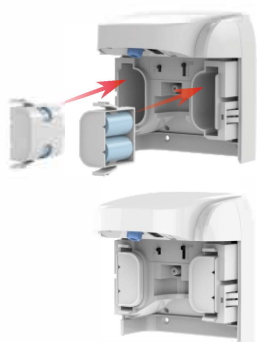

C - Size Battery x 4

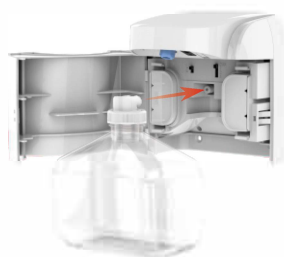

1000ml PET bottle



Dosage is adjustable



Disposable pump is not required, cost saving

Coming Soon



Mini Pumpless Automatic Foam Soap Dispenser

7910

- Patented air compressor design. No disposable pump required. Cost saving and eco-friendly
- Touch less sensor
- Table try or mounting plate support
- Cover opens from side for easy refilling
- Adjustable dosage
- Operates with 4xAA alkaline batteries (LR6)
- Compatible with refillable bottles larger than 500ml (customizable bottle size). Default bottle size is 500ml

Material	Dimension	Packaging	Carton Size	G.W/kg
PP	109*100.5*178	6PCS/CTN	230*315*190	6.5

Battery:
AA-Size X 4pcs



500ml



Disposable pump is not required, cost saving

Automatic Soap Dispenser



•7810A-AH78
customized decor



•SL-710A-AH78

Pumpless Automatic Foam Soap Dispenser

7810A and SL-710A

- Patented air compressor design. No disposable pump required. Cost saving and eco-friendly
- Touch less infrared sensor
- Adjustable dosage
- Operates with 4xC alkaline batteries (LR14)
- Compatible with 1100ml refillable bottle or 800ml disposable pouch
- Color options: white and customized colors

Material	Dimension	Packaging	Carton Size	G.W/kg
pp	140*114*257	12PCS/CTN	570*460*300	12



AH-78F Auto Foam
C size Battery x 4



AH-78L Auto Liquid
C size Battery x 4



Disposable pump is not required, cost saving

Patent



Permanent Auto Foam Mechanism



Automatic Soap Dispenser

7840A

- Waterproof level: IPX4
- Innovative product of helical hear system. Higher force with less noise
- Window for refill visibility
- Supported by Hygienekey APP
- Operates with 4xAA alkaline batteries (LR6)
- Compatible with 900ml refillable bottle or 600ml disposable pouch
- Compatible with foam, lotion, and spray pump
- Color options: white and customized colors

Material	Dimension	Packaging	Carton Size	G.W/kg
ABS	126*117*261	12PCS/CTN	390*485*280	12

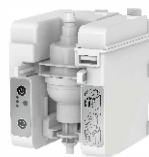

AH-76N
AA-Size Battery x 4
5V DC power supply

2023
NEW



AH-76NX
AA-Size Battery x 4
5V DC power supply

Available for 0.6ml durable pump



Available for DC power
OUTPUT:5V==1A



FPK-01



0.4ml



FPK-04N



0.4ml

Durable



FPK-15



0.6ml

Durable



LPK-12



1.0ml



LPK-15



0.6ml

Durable



SPK-12



1.0ml

Automatic Soap Dispenser



•7810A-AH76
customized decor



•SL-710A-AH76

Automatic Soap Dispenser

7810A and SL-710A

- Waterproof level: IPX4
- Innovative product of helical gear system. Higher force with less noise
- Touch less infrared sensor
- Quick refill loading design. Simple one click to load refill
- Supported by Hygienekey APP
- Operates with 4xAA alkaline batteries (LR6)
- Compatible with 1100ml refillable bottle or 800ml disposable pouch
- Compatible with foam, lotion, and spray pump
- Color options: white and customized colors

Material	Dimension	Packaging	Carton Size	G.W/kg
PP	140*114*257	12PCS/CTN	570*460*300	11.8



800ml
Soft
Pouch



1100ml
HDPE
Bottle



AH-76N
AA-Size Battery x 4
5V DC power supply

**2023
NEW**



AH-76NX
AA-Size Battery x 4
5V DC power supply
Available for 0.6ml durable pump



Available for DC power
OUTPUT:5V=1A

2 Optional Cartridges

FPK-01



0.4ml

**2022
NEW**

FPK-04N



Durable

0.4ml

**2022
NEW**

FPK-15



Durable

0.6ml

LPK-12



1.0ml

**2022
NEW**

LPK-15



Durable

0.6ml

SPK-12



1.0ml

Automatic Soap Dispenser



7200A



7300A



7500A

Hi: 260mm

Automatic Soap Dispenser

7200A , 7300A and 7500A

- Waterproof level: IPX4
- Innovative product of helical hear system. Higher force with less noise
- Touch less infrared sensor
- Quick refill loading design. Simple one click to load refill
- Supported by Hygienekey APP
- Operates with 6xAA alkaline batteries (LR6)
- Compatible with 1000ml refillable bottle or disposable pouch
- Compatible with foam, lotion, and spray pump
- Color options: white and customized colors

Material	Dimension	Packaging	Carton Size	G.W/kg
PP	123*120*260	12PCS/CTN	525*420*290	10.8



2 Optional Cartridges



AH-72 Auto
AA-Size Battery x 6



AH-72 N
AA-Size Battery x 6
Available for 0.6ml durable pump



Available for DC power
OUTPUT:5V=1A

FPK-01



0.4ml

2022
NEW

FPK-04N



0.4ml

Durable

2022
NEW

FPK-15



0.6ml

Durable

LPK-12



1.0ml

2022
NEW

LPK-15



0.6ml

Durable

SPK-12



1.0ml

Automatic Soap Dispenser

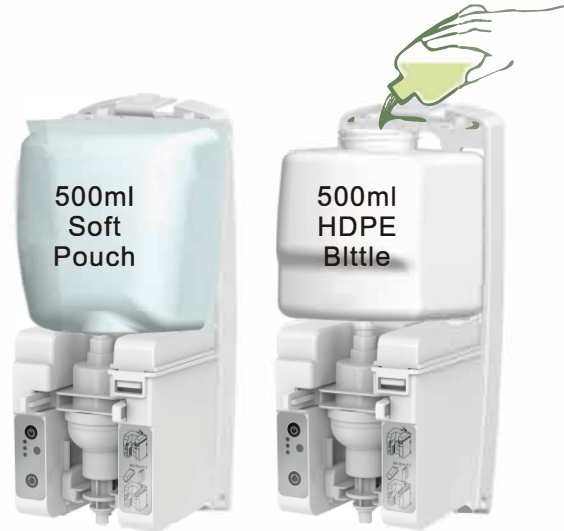

2 Optional Cartridges

Mini Automatic Soap Dispenser

7600A

- Waterproof level: IPX4
- Innovative product of helical hear system. Higher force with less noise
- Touch less infrared sensor
- Quick refill loading design. Simple one click to load refill
- Supported by Hygienekey APP
- Operates with 4xAA alkaline batteries (LR6)
- Compatible with 1000ml refillable bottle or disposable pouch
- Compatible with foam, lotion, and spray pump

Material	Dimension	Packaging	Carton Size	G.W/kg
PP	103*103*222	12PCS/CTN	453*347*250	8



AH-76N
AA-Size Battery x 4
5V DC power supply

2023
NEW



AH-76NX
AA-Size Battery x 4
5V DC power supply

Available for 0.6ml durable pump



Available for DC power
OUTPUT:5V=1A

FPK-01



0.4ml

2022
NEW

FPK-04N



0.4ml

Durable

2022
NEW

FPK-15



0.6ml

Durable

LPK-12



1.0ml

2022
NEW

LPK-15



0.6ml

Durable

SPK-12



1.0ml

Manual Soap Dispenser



7810M
customized decor



SL-710M

Manual Soap Dispenser

7810M

- Special design push bar
- Quick refill loading design. Simple one click to load refill
- Compatible with 1200ml refill bottle or 1000ml disposable pouch
- Compatible with foam, lotion, and spray pump
- Color options: white and customized colors

Material	Dimension	Packaging	Carton Size	G.W/kg
PP	140*130*260	12PCS/CTN	570*460*290	10.67



2 Optional Cartridges

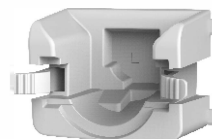

AH-78M

Manual Soap Dispenser



Manual Soap Dispenser

7200M

- Special design push bar
- Quick refill loading design. Simple one click to load refill
- Compatible with 1000ml refill bottle or 800ml disposable pouch
- Compatible with foam, lotion, and spray pump
- Color options: white and customized colors

Material	Dimension	Packaging	Carton Size	G.W/kg
PP	123*125*260	12PCS/CTN	525*420*290	8.4

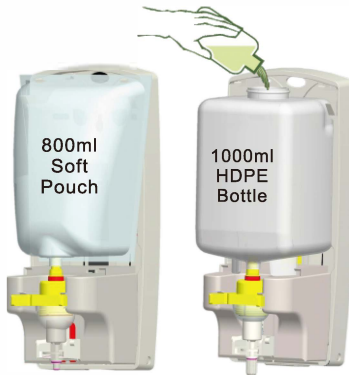

2 Optional Cartridges

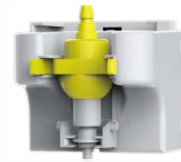

AH-72M

FPK-01



0.4ml

FPK-04N



0.4ml

LPK-12



1.0ml

SPK-12



1.0ml



Manual Soap Dispenser

7210M

- Special design push bar
- Quick refill loading design. Simple one click to load refill
- Compatible with 1400ml refill bottle or 1500ml disposable pouch
- Compatible with foam, lotion, and spray pump
- Color options: white and customized colors

Material	Dimension	Packaging	Carton Size	G.W/kg
PP	123*125*260	12PCS/CTN	520*420*290	8.2

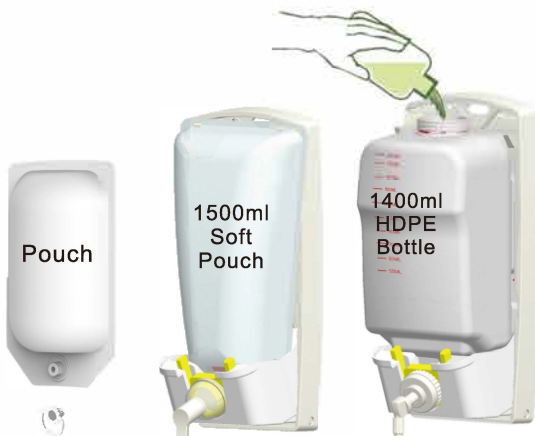

Seal Pull Plug

2 Optional Cartridges



AH-721M

FPK-02



0.4ml

FPK-05



0.4ml

LPK-13



1.0ml

SPK-13



1.0ml

Manual Soap Dispenser



Mini Manual Soap Dispenser

7600M

- Special design push bar
- Quick refill loading design. Simple one click to load refill
- Compatible with 750ml refill bottle or 800ml disposable pouch
- Compatible with foam, lotion, and spray pump
- Color options: white and customized colors

Material	Dimension	Packaging	Carton Size	G.W/kg
PP	108*103*222	12PCS/CTN	453*347*250	6.55

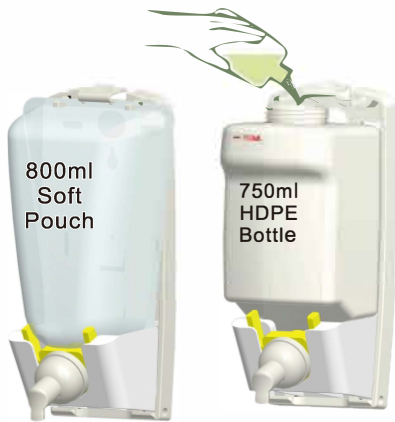

2 Optional Cartridges

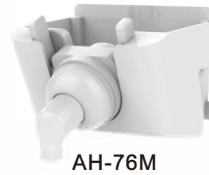

AH-76M

FPK-02



0.4ml

FPK-05



0.4ml

LPK-13



1.0ml

SPK-13



1.0ml



Manual Soap Dispenser

7840M

- Full cover lever push design
- Window for refill visibility
- Compatible with 900ml refillable bottle or 600ml disposable pouch
- Compatible with foam, lotion, and spray pump
- Color options: white and customized colors

Material	Dimension	Packaging	Carton Size	G.W/kg
PP	126*117*261	12PCS/CTN	390*485*280	12



2 Optional Cartridges



ES-04M

FPK-01



0.4ml

2022 NEW

FPK-04N



0.4ml

2022 NEW

FPK-15



0.6ml

LPK-12



1.0ml

2022 NEW

LPK-15



0.6ml

SPK-12



1.0ml

Manual Tubing Soap Dispenser



H: 286mm

Manual Tubing Soap Dispenser

7200MT

- Special design push bar
- Working with soap tubes
- Compatible with 1000ml disposable refill pouch
- Color options: white and customized colors

Material	Dimension	Packaging	Carton Size	G.W/kg
PP	135*121*286	12PCS/CTN	545*410*310	11.8



TPV-03
tubing pump valve

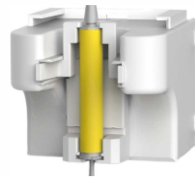

AH-75MTL



H: 286mm

Manual Tubing Soap Dispenser

7500MT

- Special design push bar
- Working with soap tubes
- Compatible with 1000ml disposable refill pouch
- Color options: white and customized colors

Material	Dimension	Packaging	Carton Size	G.W/kg
PP	135*121*286	12PCS/CTN	545*410*310	11.8



TPV-03
tubing pump valve

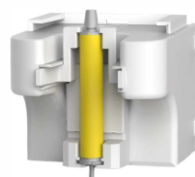

AH-75MTL



HAND/SURFACE CLEANER DISPENSER



Hand/Surface Cleaner Dispenser



Hand/Surface Disinfectant Dispenser

7100

- Easy Refill Design: Top opening with a visible refill level
- Touch less sensor
- Table top or mounting plate support
- Adjustable dosage: 0.8ml/1.5ml/ or customized
- Operates with 4xAA alkaline batteries (LR6)
- Compatible with 600ml refill
- Color options: white and customized colors

Material	Dimension	Packaging	Carton Size	G.W/kg
PP	117*119*215	12PCS/CTN	500*390*240	7.2

REFILLABLE

Coming Soon



Dosage ⇒ 0.8ml/1.5ml
AA-Size Battery x 4

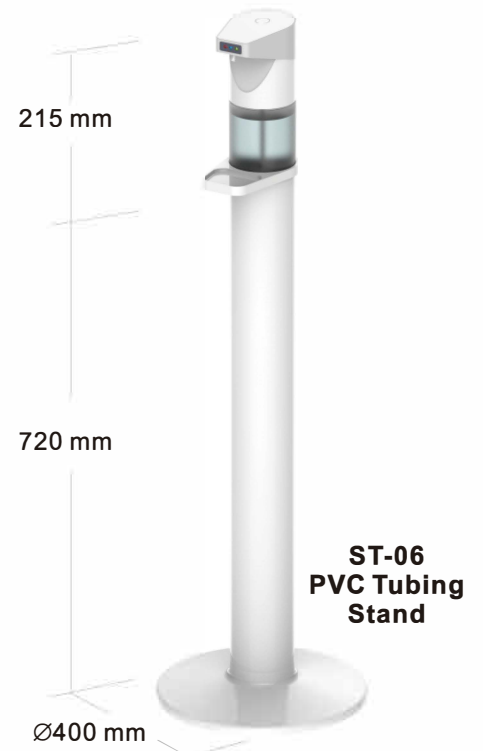
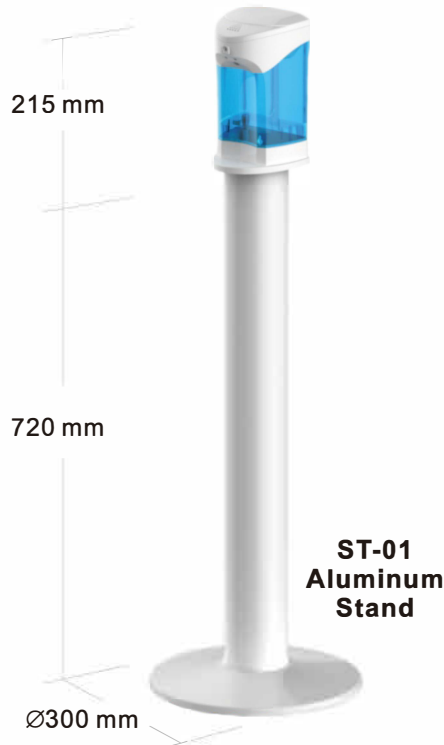

Hand/Surface Cleaner Dispenser



Manual Hand/Surface Cleaner Dispenser

SL-720MS

- Multifunctional use for toilet seat cleaner, hand disinfectant, etc., based on refill and pump
- Compact Design and easy installation
- Compatible with 600ml refillable bottle or 500ml disposable pouch
- Compatible with 7 optional spray pumps
- Color options: white and customized colors

Material	Dimension	Packaging	Carton Size	G.W/kg
PP	93*108*204	12PCS/CTN	420*335*225	5.6

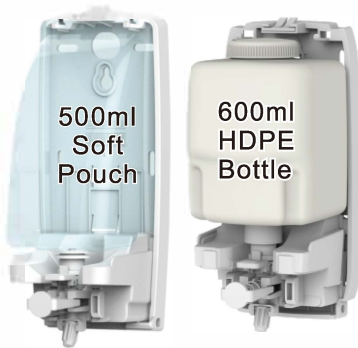

2 Optional Cartridges



AH-720MS

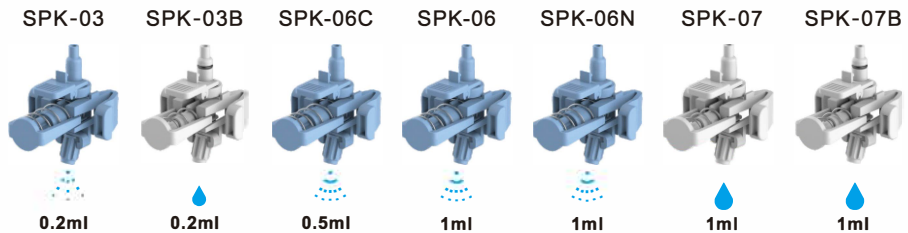

•7700M

Manual Hand/Surface Cleaner Dispenser

7700M

- Multifunctional use for toilet seat cleaner, hand disinfectant, etc., based on refill and pump
- Compact Design and easy installation
- Compatible with 450ml refillable bottle or 400ml disposable pouch
- Compatible with 7 optional spray pumps
- Color options: white and customized colors

Material	Dimension	Packaging	Carton Size	G.W/kg
PP	102*85*225	36PCS/CTN	560*350*500	11



2 Optional Cartridges



AH-77M

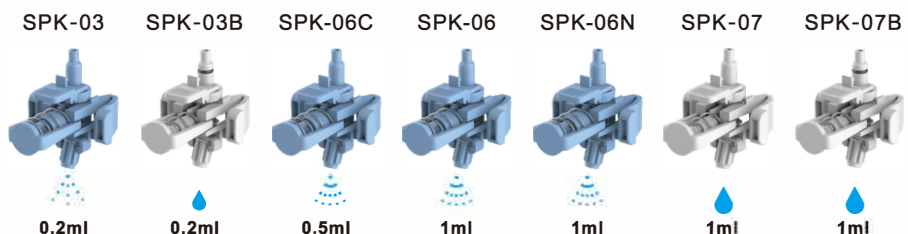

Hand/Surface Cleaner Dispenser

**2022
NEW**



Pedal Touchless Disinfectant Dispenser

7420M

- Battery Free. Pedal to dispense
- Easy and quick loading design
- Stable, wide and heavy base plate of 4.6kg
- Dosage Option: 2ml mist spray

Material	Dimension	Packaging	Carton Size	G.W/kg
ABS	400*400*1115	2PCS/CTN	860*465*140	9.2

Loading bottle from the back

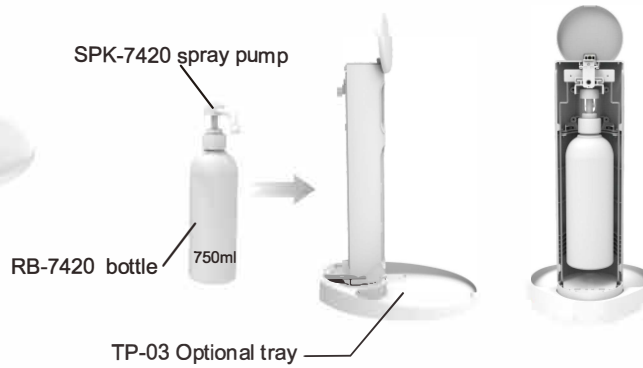

USAGE SCENARIO

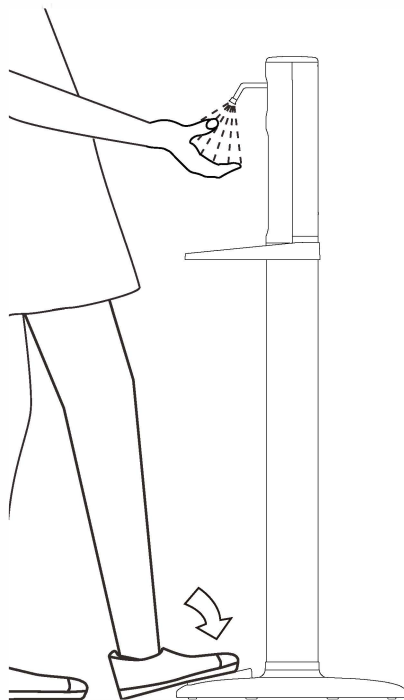

Step on the pedal to disinfect your hands.

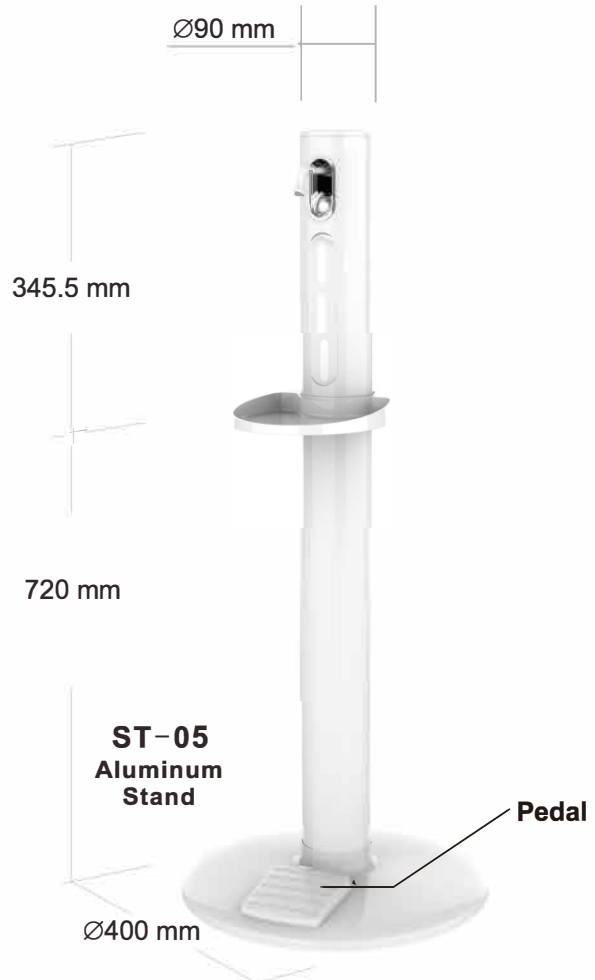

Hand/Surface Cleaner Dispenser



Mini Manual Hand/Surface Cleaner Dispenser

EL-730

- Multifunctional use for toilet seat cleaner, hand disinfectant, etc., based on refill and pump
- Compact Design and easy installation
- Compatible with 350ml refillable bottle or disposable pouch
- Compatible with 5 optional spray pumps
- Color options: white and customized colors

Material	Dimension	Packaging	Carton Size	G.W/kg
ABS	86*77*198	30PCS/CTN	455*305*450	11



SPK-03



SPK-06C



SPK-06



SPK-06N



SPK-07

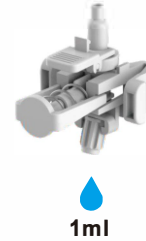

Manual Hand/Surface Cleaner Dispenser

4100M

- No battery with continuous valve
- Multifunctional use for toilet seat cleaner, hand disinfectant, etc., based on aerosol refill used
- Patented Loading and Releasing system
- Compatible with 400ml aerosol refills
- Color options: white and customized colors

Material	Dimension	Packaging	Carton Size	G.W/kg
PP	92*90*235	30PCS/CTN	490*320*520	11.3

Patent



Quick Mounting Device For Canister



Patented Quick Load/Release Refill Design

Use continuous valve



Aerosol Refill

Hand/Surface Cleaner Dispenser



H: 231mm

Touchless Hand Disinfectant Dispenser

7400

- Compact Design and easy installation
- Table tray, mounting plate support, or use with aluminum stand ST-01
- Stable, wide and heavy base plate of 4.6kg
- Dosage option: 0.12ml mist spray with adjustable dispense frequency of 1,2,3 times
- Compatible with 300ml refill
- Color options: white and customized colors

Material	Dimension	Packaging	Carton Size	G.W/kg
ABS	92*90*231	20PCS/CTN	530*440*290	11.7

REFILLABLE BOTTLE

TP-03 tray



Ø90 mm

231.5 mm

720 mm

ST-01
Aluminum
Stand

Ø300 mm

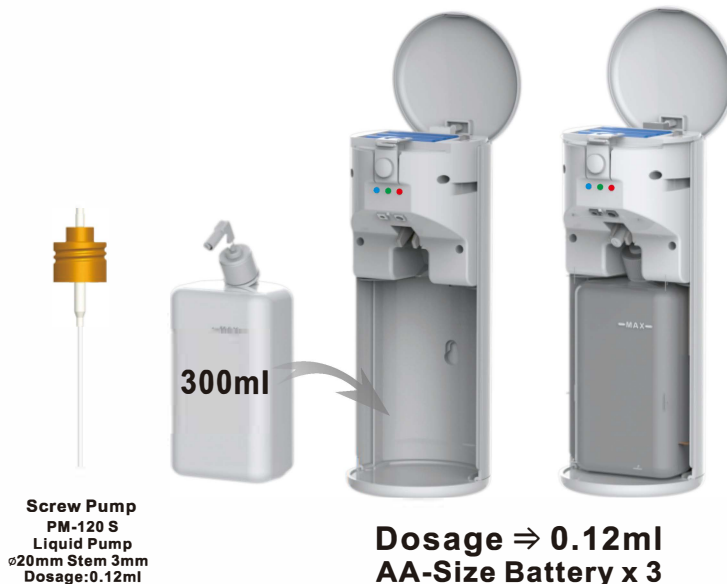

Screw Pump
PM-120 S
Liquid Pump
Ø20mm Stem 3mm
Dosage:0.12ml

300ml

Dosage ⇒ 0.12ml
AA-Size Battery x 3

Hand/Surface Cleaner Dispenser

**2022
NEW**



Automatic Disinfectant Dispenser

7420A

- Compact Design and easy installation
- Table tray, mounting plate support, or use with aluminum stand ST-01
- Stable, wide and heavy base plate of 4.6kg
- Dosage option: 0.5ml mist spray with adjustable dispense frequency of 1,2,3 times
- Compatible with 650ml refill. Customized sizes are made upon request
- Color options: white and customized colors

Material	Dimension	Packaging	Carton Size	G.W/kg
ABS	400*400*1115	2PCS/CTN	860*465*140	9.2

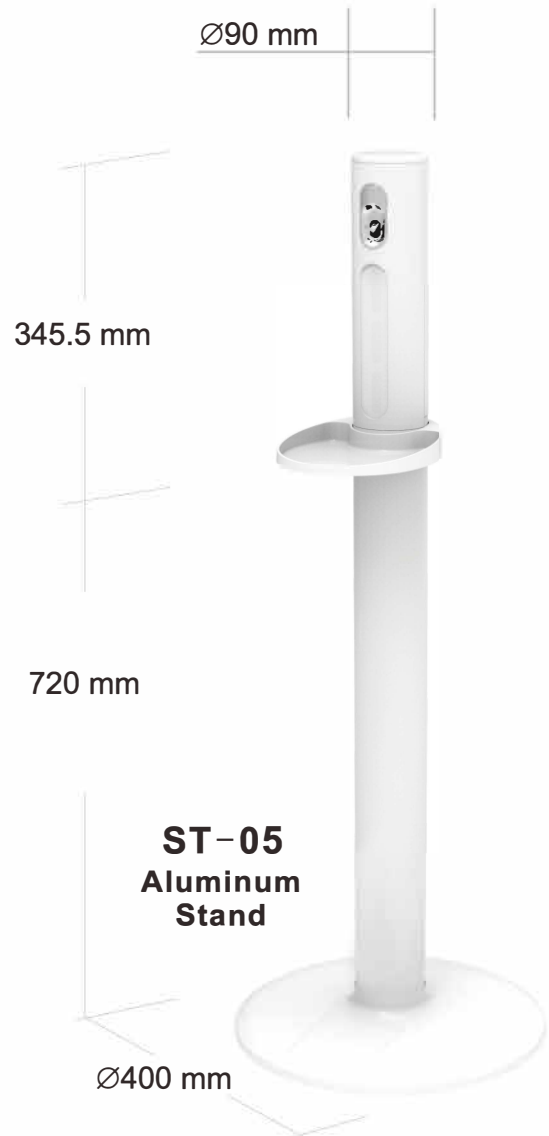
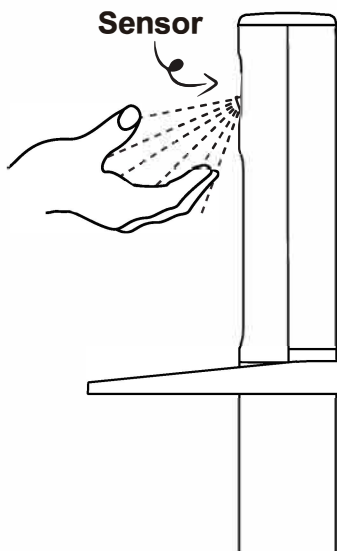
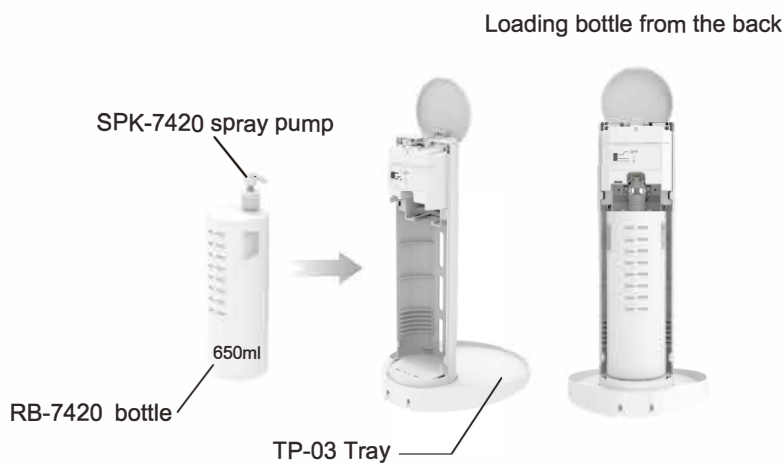

Hand/Surface Cleaner Dispenser



H: 230mm

Manual Hand/Surface Cleaner Dispenser

7620M

- Multifunctional use for toilet seat cleaner, hand disinfectant, etc., based on refill and pump
- Compact Design and easy installation
- Compatible with 700ml refill
- Compatible with 5 optional permanent pumps and 4 durable pump
- Color options: white, black and customized colors

Material	Dimension	Packaging	Carton Size	G.W/kg
PP	108*105*230	12PCS/CTN	330*250*450	6.4

Refillable



SPK-03



SPK-06C



SPK-06



SPK-06N



SPK-07

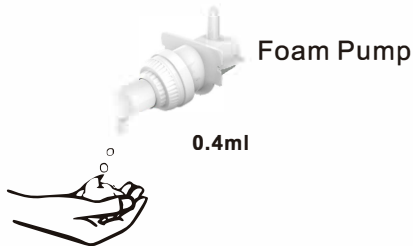
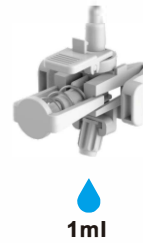

Durable Foam Pump

FPK-72B



FPK-72NB



LPK-72NB



SPK-72NB



FAN DISPENSER



Fan Dispenser



•9100

•9200



H: 248mm

•9210

Fan Driven Aroma Dispenser

9100 and 9200

- Two optional front covers: 9100 and 9200
- Special air flow design to spread the fragrance more efficiently
- Working with 1pcs D size alkaline battery (LR20)
- Working mode is 24 hours, once power turned ON
- Universal design for popular size aroma gels, fragrance liquid cans and wooden wicks
- Security key and lock
- Polypropylene material, eco-friendly and chemical-resistant
- Color options: white and customized colors

9210

- Elegant design, with special air flow design to spread the fragrance more efficiently
- Working with 1pcs D size alkaline battery (LR20)
- Three working modes: Day, Night and 24 hours
- Three working programs to adjust fragrance intensity:
 - 1 minute ON, 1 minute OFF
 - 1 minute ON, 2 minutes OFF
 - 1 minute ON, 3 minutes OFF
- Universal design for popular size aroma gels, fragrance liquid cans and wooden wicks
- Security key and lock
- Polypropylene material, eco-friendly and chemical-resistant
- Color options: white, black and customized colors

Material	Dimension	Packaging	Carton Size	G.W/kg
PP	97*86*248	30PCS/CTN	550*310*530	12.11

D-Size Battery x 1

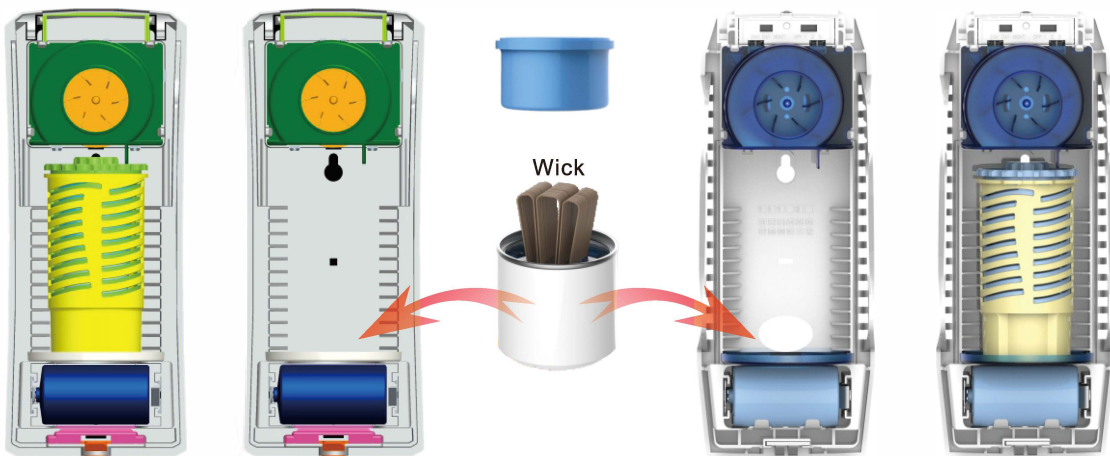

9100 & 9200

9210



FC-92
100ml Pop-top
Fragrance liquid can



Lavender
FC-LA9100



Rose
FC-RO9100



Lemon
FC-LE9100



Ocean
FC-OC9100

Available fragrance and more

Fan Dispenser



• 9300



• 9310

Fan Driven Aroma Dispenser

9300 and 9310

- Two optional front covers: 9300 and 9310
- Special air flow design to spread the fragrance more efficiently
- Working with 2pcs C size alkaline batteries (LR14)
- Three working programs to adjust fragrance intensity:
 - 24 hours ON
 - 2 minutes ON, 2 minutes OFF
 - 1 minute ON, 3 minutes OFF
- Universal design for popular size aroma gels, fragrance liquid cans and wooden wicks
- Security key and lock
- Polypropylene material, eco-friendly and chemical-resistant
- Color options: white, black and customized colors

Material	Dimension	Packaging	Carton Size	G.W/kg
PP	132*85*195	12PCS/CTN	440*380*230	5.2



Fan Dispenser



Hi: 122mm

Fan Driven Aroma Dispenser (Table Top)

9400

- Table top for variety used
- Working with 1pcs D size alkaline battery (LR20)
- Working mode: Working constantly only when light is on
- Universal design for popular size aroma gels, fragrance liquid cans and wooden wicks.
- Polypropylene material, eco-friendly and chemical-resistant
- Color options: white and customized colors

Material	Dimension	Packaging	Carton Size	G.W/kg
PP	96*96*122	12PCS/CTN	450*340*150	2

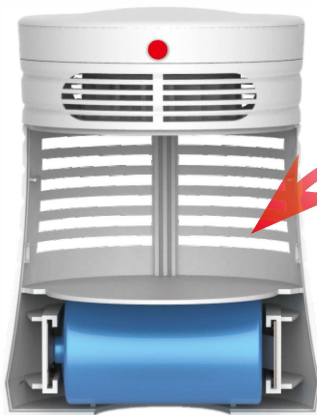

D-Size Battery x 1

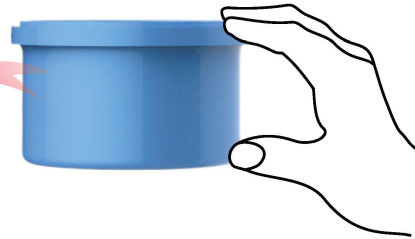

Light Sensor

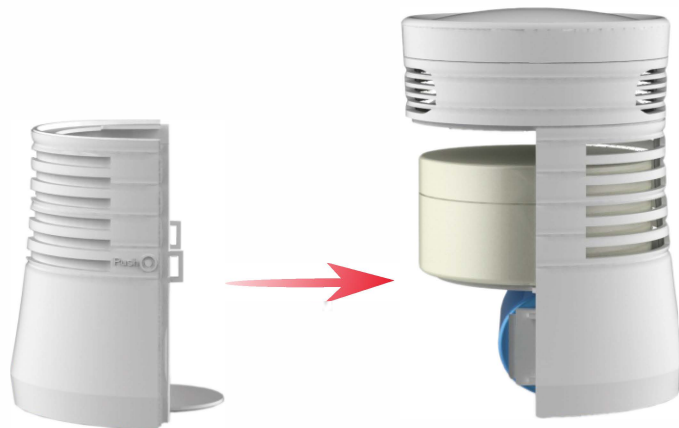

SANITIZER DISPENSER

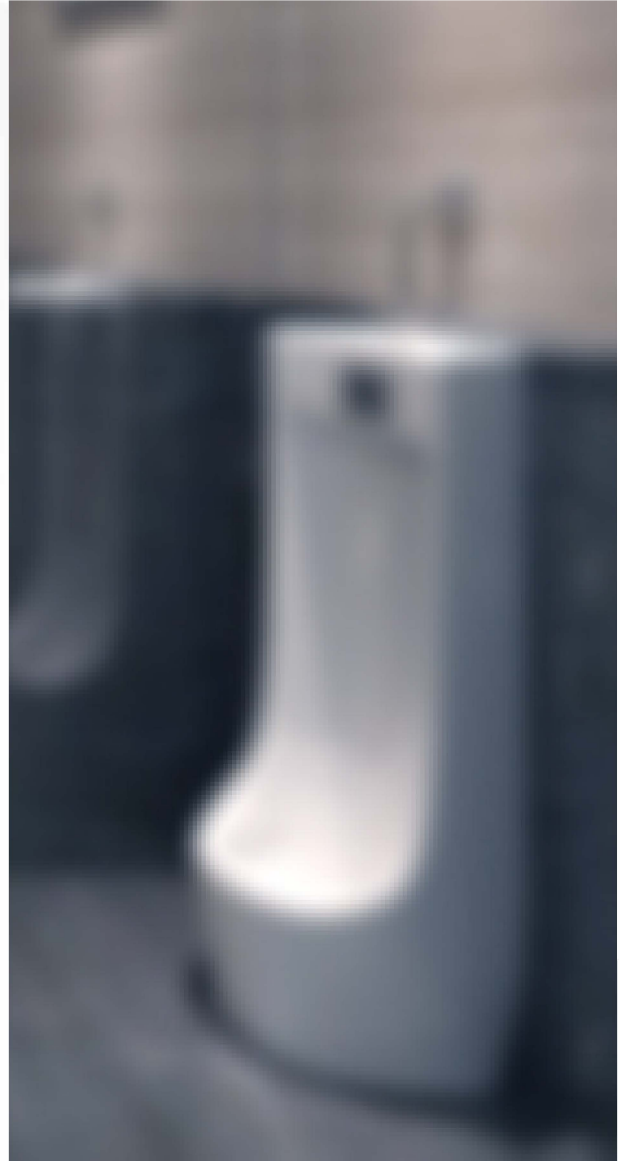

Toilet/Urinal Sanitizer Dispenser



•8300

•8310

•8320

Automatic Sanitizer Dispenser

8300 , 8310 and 8320

- Three versions: Programmable LCD, Economy LED, and Hygienekey APP Version
- Waterproof design on motor and PCB
- Operates with 2xC alkaline batteries (LR14)
- Compatible with 550ml refillable bottle or disposable pouch
- Pump Options: Screw pump and crimping pump. Dosage at 0.12ml
- Color options: white, and customized colors

Material	Dimension	Packaging	Carton Size	G.W/kg
PP	140*80*226	12PCS/CTN	460*410*280	8

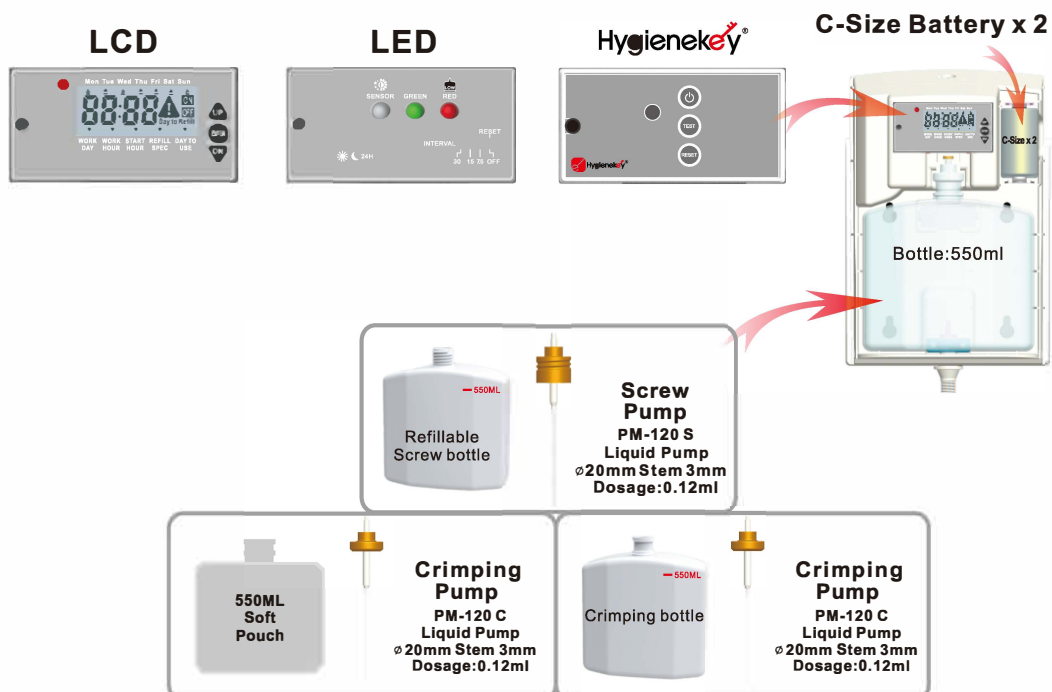

Toilet/Urinal Sanitizer Dispenser



•8200LCD Programmable

•8200LED Economy

Automatic Sanitizer Dispenser

8200

- Dual function: Fragrance diffusing and sanitizing through absorbent wick and reservoir
- Two versions: Programmable LCD, Economy LED
- Waterproof design on motor and PCB
- Operates with 2xC alkaline batteries (LR14)
- Compatible with 700ml refillable bottle or disposable pouch
- Pump Options: Screw pump and crimping pump. Dosage at 0.12ml
- Color options: white, and customized colors

Material	Dimension	Packaging	Carton Size	G.W/kg
PP	150*89*230	12PCS/CTN	470*400*270	16.1

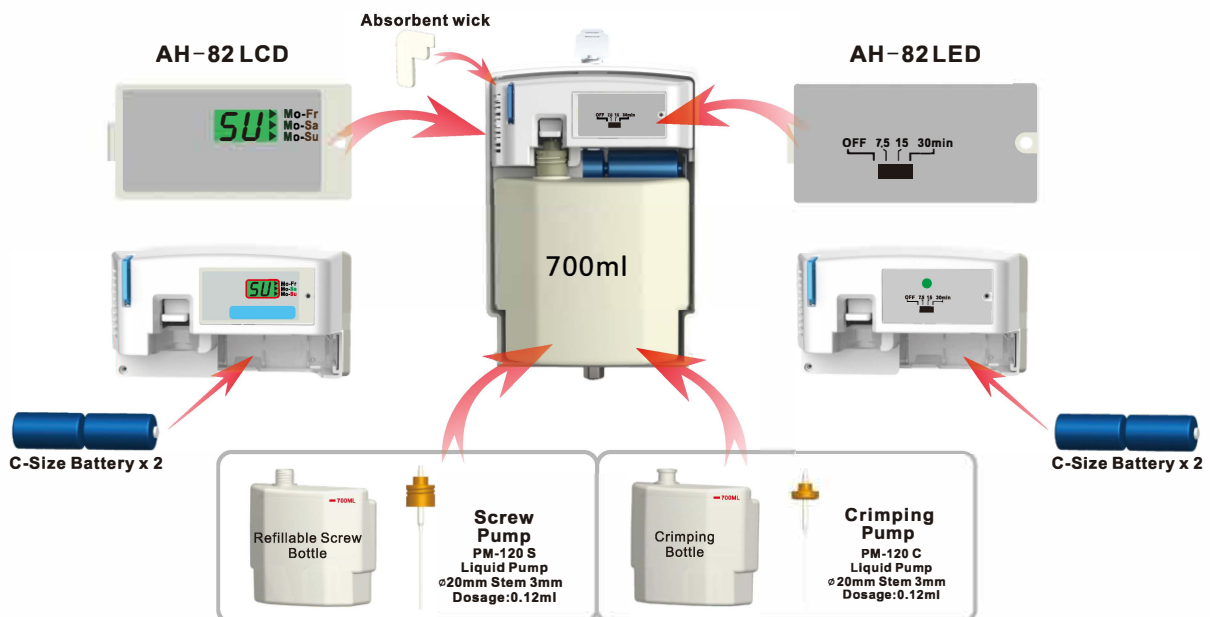

Toilet/Urinal Sanitizer Dispenser



Automatic Sanitizer Dispenser

8400

- Three versions: Programmable LCD, Economy LED, and Hygienekey APP Version
- Waterproof design on motor and PCB
- Operates with 2xC alkaline batteries (LR14)
- Compatible with 400ml refillable bottle or disposable pouch
- Pump Options: Screw pump and crimping pump. Dosage at 0.12ml
- Color options: white, and customized colors

Material	Dimension	Packaging	Carton Size	G.W/kg
PP	110*80*228	12PCS/CTN	360*350*250	6.69

AH-84LCD



AH-84LED



AH-84BT



Hygienekey®

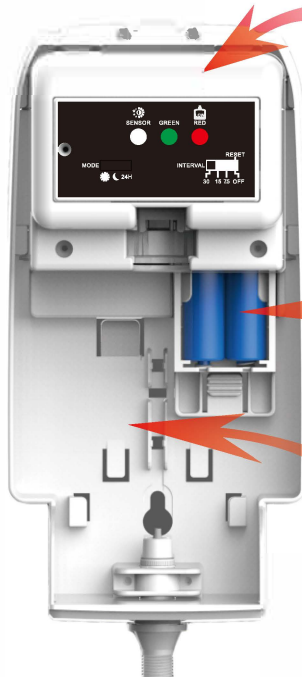

AA-Size Battery x 2

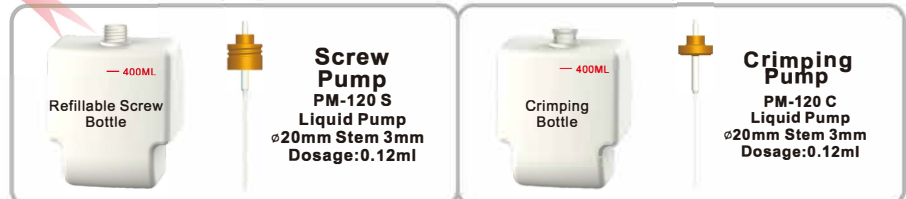

Toilet/Urinal Sanitizer Dispenser



Automatic Sanitizer Dispenser

8500

- Dual function: Fragrance diffusing and sanitizing through absorbent wick and reservoir
- Three versions: Programmable LCD, Economy LED, and Hygienekey APP Version
- Waterproof design on motor and PCB
- Operates with 2xC alkaline batteries (LR14)
- Compatible with 350ml refillable bottle or disposable pouch
- Pump Options: Screw pump and crimping pump. Dosage at 0.12ml
- Color options: white, and customized colors

Material	Dimension	Packaging	Carton Size	G.W/kg
PP	140*80*190	12PCS/CTN	450*335*230	7

8500LCD

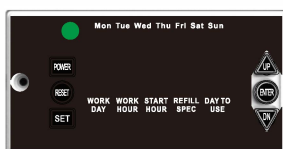

8500LED

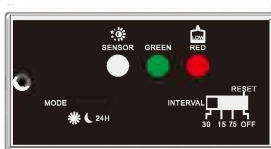

8500BT

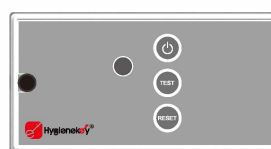

Hygienekey®

C - Size Battery x 2

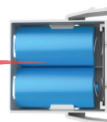

Absorbent wick

Reservoir

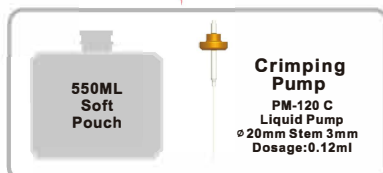
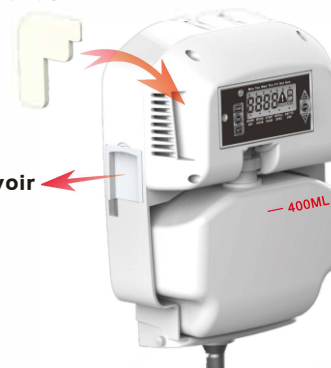

Toilet/Urinal Sanitizer Dispenser



Drip Type Sanitizer Dispenser

8200C

- Battery free: upside down bottle on reservoir, using pressure theory to drip automatically
- Dual function: fragrance diffusing and sanitizing through absorbent wick and the reservoir
- Refill capacity: 1000ml
- Color options: white and customized colors

Material	Dimension	Packaging	Carton Size	G.W/kg
PP	149*89*230	12PCS/CTN	470*400*270	7.3



Reservoir

Wick



Drip Type Sanitizer Dispenser

8400C

- Compact design
- Battery free: upside down bottle on reservoir, using pressure theory to drip automatically
- Dual function: fragrance diffusing and sanitizing through absorbent wick and the reservoir
- Refill capacity: 500ml
- Security key and lock
- Polypropylene material, eco-friendly and chemical-resistant
- Color options: white and customized colors

Material	Dimension	Packaging	Carton Size	G.W/kg
PP	110*80*200	12PCS/CTN	360*350*250	5.6



Reservoir

Wick

AEROSOL DISPENSER



1100 Series of Aerosol Dispenser



H: 220mm

1100 Series of Aerosol Dispenser

- Compatible with 5 base options: C-LED, AA-LED, AA-LCD, Remote Control, and Interchangeable T
- C-LED: operates with 2xC alkaline batteries (LR14). Compatible with 270ml refill
- AA-LED, AA-LCD and Remote Control operates with 2xAA alkaline batteries (LR6). Compatible with 270ml or 300ml refill
- Eco friendly recyclable PP material. Chemical-resistant
- Color options: white, and customized colors

Material	Dimension	Packaging	Carton Size	G.W/kg
PP	104*83*220	30PCS/CTN	465*300*460	11.85

•1100
chromed decor



•1200
chromed decor



•1200T
Interchangeable
action head
AH-28-4C
AH-28-5B



•1300



•1400



•1800

DESIGN FOR UNIVERSAL REFILL



C-LED
Battery: 2pcs C size
Working mode: Day/Night/24Hour
Interval: 7.5/15/30 minutes
Refill: 270ml

AA-LED
Battery: 2pcs AA size
Working mode: Day/Night/24Hour
Interval: 7.5/15/30 minutes
Refill: 270ml/300ml

AA-LCD
Battery: 2pcs AA size
Programmable
Refill: 270ml/300ml

2100 Series of Aerosol Dispenser



H: 231 mm

•2100

chromed decor



•2200

chromed decor



•2400

2100 Series of Aerosol Dispenser

- Adjustable working modes and interval settings
- Operates with 2xC alkaline batteries (LR14)
- Compatible with 270ml or 300ml refill
- Eco friendly recyclable PP material. Chemical-resistant
- Color options: white, and customized colors

Material	Dimension	Packaging	Carton Size	G.W/kg
PP	95*89*231	30PCS/CTN	500*290*520	13.6

DESIGN FOR UNIVERSAL REFILL



C-LED

Battery: 2pcs C size
Working mode: Day/Night/24Hour
Interval: 7.5/15/30 minutes
Refill: 270ml



C-LED

Battery: 2pcs C size
Working mode: Day/Night/24Hour
Interval: 7.5/15/30 minutes
Refill: 300ml

3100 Series of Aerosol Dispenser



•3100

•3200

•3310

3100 Series of Aerosol Dispenser

- Interchangeable action head design. Easy installation and quick changes
- Three versions: Programmable LCD, Economy LED, and Hygienekey APP Version
- Operates with 2xAA alkaline batteries (LR6)
- Compatible with 270ml refill
- Eco friendly recyclable PP material. Chemical-resistant
- Color options: white, and customized colors

Material	Dimension	Packaging	Carton Size	G.W/kg
PP	84*78*207	30PCS/CTN	470*300*460	13.2



Refill size:
Dia: ϕ 65mm
H: 120mm
Vol: 270ml

AH-12

LCD



MODEL:AH-11



MODEL:AH-12



MODEL:AH-16



MODEL:AH-17

LED



MODEL:AH-21



MODEL:AH-22

Hygienekey[®]



MODEL:AH-22BT

Optional Action Heads

Action Head Series of Aerosol Dispenser

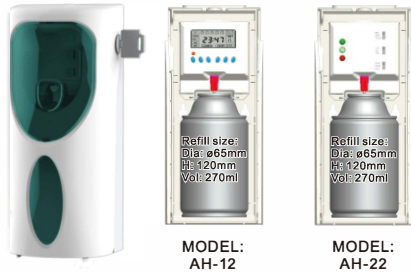

MODEL:
AH-12

MODEL:
AH-22

•3210
80(L)*85(W)*216.5(H) mm



MODEL:
AH-12

MODEL:
AH-22

•3300
82.5(L)*77.5(W)*247(H) mm



MODEL:
AH-13

MODEL:
AH-23

•1020
85(L)*82(W)*210(H) mm



MODEL:
AH-11

MODEL:
AH-21

•2001
85(L)*82(W)*207(H) mm

Action Head Series of Aerosol Dispenser

- Interchangeable action head design. Easy installation and quick changes
- Three versions: Programmable LCD, Economy LED, and Hygienekey APP Version
- Operates with 2xAA alkaline batteries (LR6)
- 3210 compatible with 270ml refill. 3300 compatible with 270ml or 300ml refill
- Eco friendly recyclable PP material. Chemical-resistant
- Color options: white, and customized colors
- Action Head Series of Aerosol Dispenser

3210

Material	Packaging	Carton Size	G.W/kg
PP	30PCS/CTN	470*300*470	13

3300

Material	Packaging	Carton Size	G.W/kg
PP	30PCS/CTN	450*320*560	14.6

LCD

LED

Hygienekey[®]



Optional Action Heads

Action Head Series of Aerosol Dispenser

- Interchangeable action head design. Easy installation and quick changes
- 1020 compatible action head options: AH-13 Programmable LCD and AH-23 Economy LED
- 2001 compatible action head options: AH-11 Programmable LCD and AH-21 Economy LED
- Operates with 2xAA alkaline batteries (LR6)
- Compatible with 270ml refill
- Eco friendly recyclable PP material. Chemical-resistant
- Color options: white, and customized colors

1020

Material	Packaging	Carton Size	G.W/kg
PP	30PCS/CTN	470*300*470	13

2001

Material	Packaging	Carton Size	G.W/kg
PP	20PCS/CTN	460*200*460	8.2

LCD

LED



Interchangeable Aerosol Action Heads

Programmable LCD



MODEL: AH-11



MODEL: AH-12



MODEL: AH-16



MODEL: AH-17

Economy LED



MODEL: AH-21



MODEL: AH-22

Supporting SMART APP operation



MODEL: AH-22BT

1020 action heads



MODEL: AH-13



MODEL: AH-23

1200T and 1500T action heads



MODEL: AH-28-4C



MODEL: AH-28-4B

Mini Aerosol Dispenser action heads



MODEL: AH-10



MODEL: AH-20

1500 Series of Aerosol Dispenser



1500
chromed decor

1500T
Interchangeable
action head
AH-28-4C
AH-28-5B

1501

1502

1600

1500 Series of Aerosol Dispenser

- Compatible with 5 base options: B, C, D, R, and Interchangeable T
- Operates with 2xAA alkaline batteries (LR6)
- Compatible with 270ml refill
- Eco friendly recyclable PP material. Chemical-resistant
- Color options: white, and customized colors

Material	Dimension	Packaging	Carton Size	G.W/kg
PP	95*85*220	30PCS/CTN	470*310*450	10.8

4 Optional Bases



MODEL NO. B
Battery: 2pcs AA size
Working mode: Day/Night/24Hour
Interval: 7.5/15/30 minutes
Refill: 270ml



MODEL NO. C
Battery: 2pcs AA size
Interval: 7.5/15/30 minutes
Refill: 270ml



MODEL NO. D
Battery: 2pcs AA size
Working mode: 12Hours
Interval: 10/20 minutes
Refill: 270ml



MODEL NO. R
Battery: 2pcs AA size
Programmable by remote control
Refill: 270ml

D Size Battery Series of Aerosol Dispenser

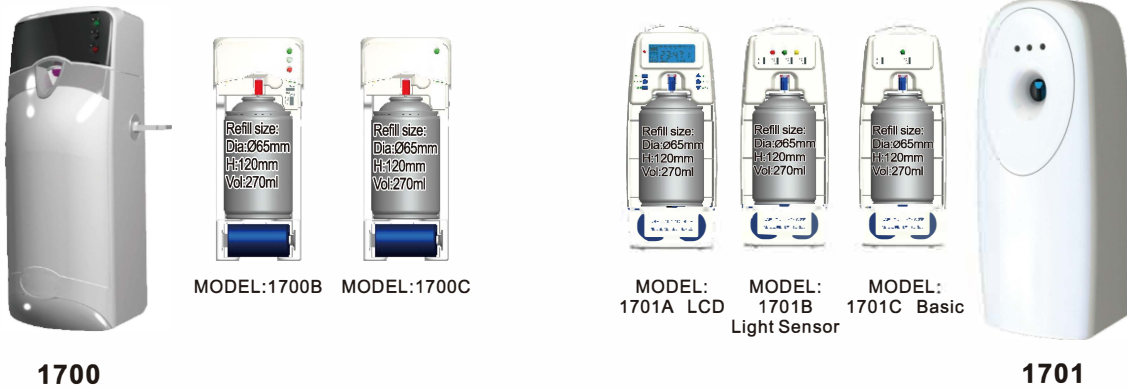

D Size Battery Series of Aerosol Dispenser

- 1700 compatible base options: B and C
- 1701 compatible base options: LCD, LED and C
- Operates with 2xD alkaline batteries (LR20)
- Compatible with 270ml refill
- Eco friendly recyclable PP material. Chemical-resistant
- Color options: white, and customized colors

1700

Material	Dimension	Packaging	Carton Size	G.W/kg
PP	87*88*220	30PCS/CTN	480*300*520	12.3

1701

Material	Dimension	Packaging	Carton Size	G.W/kg
PP	98*83*245	12PCS/CTN	340*370*270	6.22

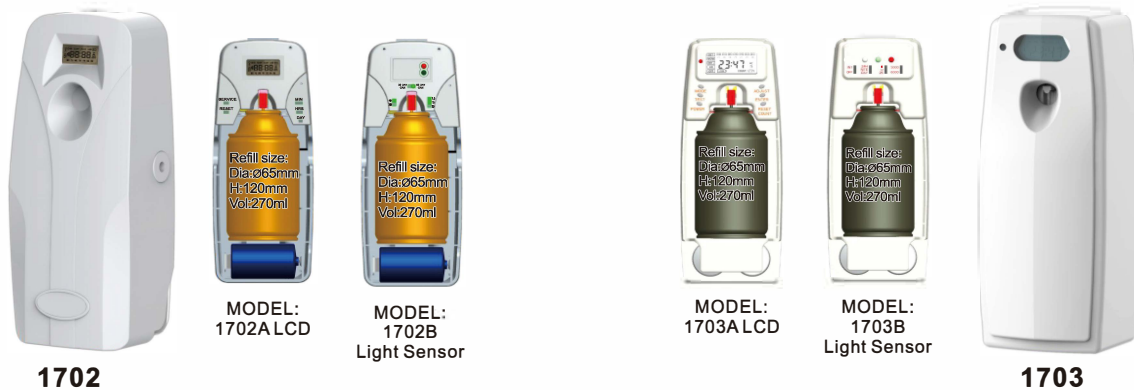

D Size Battery Series of Aerosol Dispenser

- 1702 compatible base options: B and C
- 1703 compatible base options: LCD, LED and C
- Operates with 2xD alkaline batteries (LR20)
- Compatible with 270ml refill
- Eco friendly recyclable PP material. Chemical-resistant
- Color options: white, and customized colors

1702 & 1703

Material	Dimension	Packaging	Carton Size	G.W/kg
PP	87*88*234	30PCS/CTN	510*286*495	13

Mini Aerosol Dispenser



1010



BL-520



SL-520



MODEL:
AH-10
LCD



MODEL:
AH-20
LED

Mini Aerosol Dispenser

1010, BL-520, SL-520

- Compact and portable. Open windows for LCD/LED display
- Interchangeable action head design. Easy installation and quick changes
- Two versions: AH-10 Programmable LCD and AH-20 Economy LED
- Operates with 2xAA alkaline batteries (LR6)
- Compatible with 110ml refill
- Eco friendly recyclable PP material. Chemical-resistant
- Color options: white, Icy Bluem Transparent black and customized colors

Material	Dimension	Packaging	Carton Size	G.W/kg
PP	76*60*175	30PCS/CTN	490*340*410	9.6



H: 169mm

Mini Aerosol Dispenser

1011LED

- Compact and portable
- Simple interval setting: 7.5min/15/30 mins
- Operates with 2xAA alkaline batteries (LR6)
- Compatible with 110ml refill
- Eco friendly recyclable PP material. Chemical-resistant
- Color options: white, and customized colors

Material	Dimension	Packaging	Carton Size	G.W/kg
PP	67*65*169	30PCS/CTN	450*430*210	7.55



Mini Aerosol Dispenser



H: 201mm

Mini Aerosol Dispenser

1012

- Compact and portable
- Two versions: Programmable LCD and Economy LED
- Operates with 2x alkaline batteries (LR14)
- Compatible with 110ml refill
- Eco friendly recyclable PP material. Chemical-resistant
- Color options: white, and customized colors

Material	Dimension	Packaging	Carton Size	G.W/kg
PP	88.5*56*201	30PCS/CTN	490*240*410	11.2



MODEL:
1012 LCD



MODEL:
1012 LED



H: 190mm

Mini Aerosol Dispenser

2005

- Compact and portable
- Two versions: Economy LED 200B and 2005C simple 15min interval setting
- Operates with 2x alkaline batteries (LR14)
- Compatible with 110ml refill
- Eco friendly recyclable PP material. Chemical-resistant
- Color options: white, and customized colors

Material	Dimension	Packaging	Carton Size	G.W/kg
PP	90*60*190	30PCS/CTN	485*230*410	9.51



MODEL:2005B



MODEL:2005C

Retail Aerosol Dispenser

Retail Aerosol Dispenser



•205



Refill size:
Dia: 265mm
H: 120mm
Vol: 270ml

Retail Aerosol Dispenser

205 & 206

- Designed for the Retail Market with Special Pricing
- Compact and portable
- Simple interval setting of 15 mins
- Operates with 2xAA alkaline batteries (LR6)
- 205 compatible with 270ml refill
- 206 compatible with 270ml or 300ml refill
- Eco friendly recyclable PP material. Chemical-resistant
- Color options: white, and customized colors



206S



206



•206

205

Material	Dimension	Packaging	Carton Size	G.W/kg
PP	80*55*150	30PCS/CTN	465*300*455	13.3

206

Material	Dimension	Packaging	Carton Size	G.W/kg
PP	80*57*150	30PCS/CTN	445*265*445	13.8

Mini Instant Spray Dispenser



MODEL:UA-100A



MODEL:UA-100D



MODEL:UA-100B



MODEL:UA-100E



MODEL:UA-100C



MODEL:UA-100F



Refill: ø22, 58mm(H), 13ml
Valve: 75mcl / 120sprays

Refill: ø22, 68mm(H), 15ml
Valve: 75mcl / 150sprays

Motion Sensor Dispenser

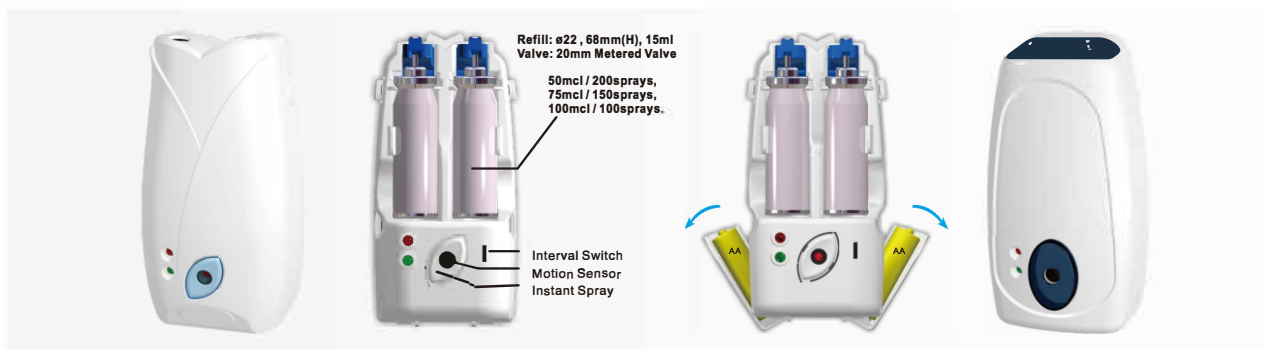

Refill: ø22, 68mm(H), 15ml
Valve: 20mm Metered Valve

50mcl / 200sprays,
75mcl / 150sprays,
100mcl / 100sprays.

Interval Switch
Motion Sensor
Instant Spray

•306

80(L)*55(W)*150(H) mm

•307

80(L)*57(W)*150(H) mm

Solenoid Valve Aerosol Dispenser

PATENT PRODUCT Solenoid Valve & Quick Mounting

Patent



Solenoid Valve "Isolated"



Solenoid Valve



Patent



Quick Mounting Device For Canister

FEATURES:

- Solenoid valve, no traditional motor-gear system needed
- Quick mounting structure
- Suitable for uses in various industries, including fragrance, odor control and pest control

BENEFITS:

- Micro size of solenoid valve
- Dose size can be adjusted to extreme small or big
- Stable spraying performance
- Easy loading solution



Ø 65mm Aerosol Refill

PATENT PRODUCT 6400



Solenoid Valve Aerosol Dispenser

6400

- Patent product with solenoid valve and quick mounting structure
- Diverse industry utilization, with special spraying angle at 45 degree upwards
- Easy loading and releasing can
- Working with 3pcs AA size alkaline batteries (LR6)
- Simple interval setting of 7.5/15/30 minutes
- Available for continuous valve and universal refill of diameter 65mm;
- Adjustable dose size with three switch options MAX/MED/MIN
- Security key and lock
- Polypropylene material, eco-friendly and chemical-resistant
- Color options: white and customized colors

Material	Dimension	Packaging	Carton Size	G.W/kg
PP	78*78*120	12PCS/CTN	280*185*290	8.3

PUMP SPRAY DISPENSER



Pump Dispenser



Liquid Pump Spray Dispenser

5500

- Elegant design, with both sides décor board available for customized colors, painted and chromed
- Spring mechanism, supplying consistent pumping force
- Specifically for non-aerosol refill use
- Working with 2pcs C size alkaline batteries (LR14)
- Two versions available: programmable LCD and economy LED
- Refill capacity: 350ml, both refillable bottle and disposable pouch available
- Crimping pump PM-100C dosage: 0.1ml, working with actuator AC-13
- Security key and lock
- Polypropylene material, eco-friendly and chemical-resistant
- Color options: white and customized colors

Material	Dimension	Packaging	Carton Size	G.W/kg
PP	127*74*190	30PCS/CTN	430*430*410	17



Cover opening upwards, for easy maintenance

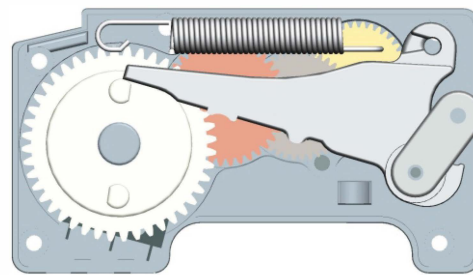

Special spring mechanism, supplying consistent pumping force, for stable spraying performance

MODEL: 5500 LCD

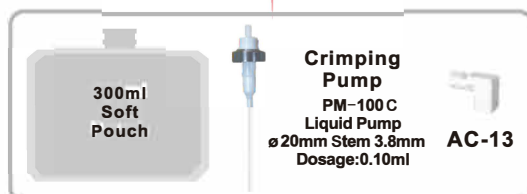
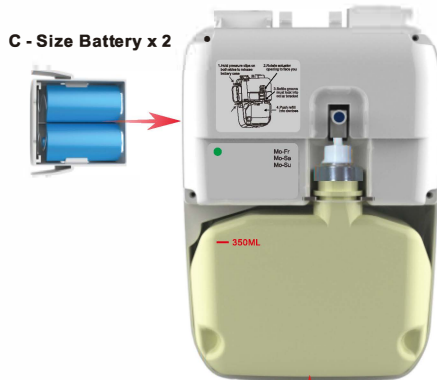

MODEL: 5500 LED

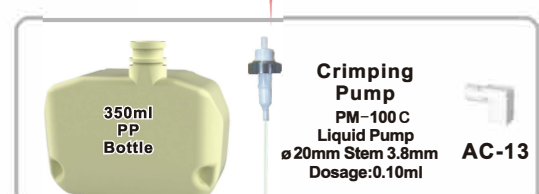
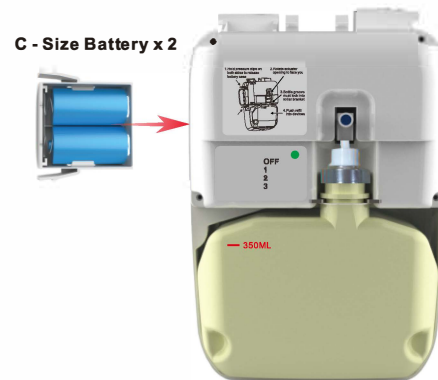

Pump Dispenser



H: 207mm

5100 Series of Liquid Pump Spray Dispenser

- For use with non-aerosol refill
- Interchangeable action head design. Easy installation and quick changes
- Two versions: Programmable LCD AH-14 and Economy LED AH-24
- Operates with 3xAA alkaline batteries (LR 6)
- Compatible with 340ml refillable bottle
- Pump option: crimping pump PM-120C dosage at 0.12ml and actuator AC-06
- Eco friendly recyclable PP material. Chemical-resistant
- Color options: white, and customized colors

Material	Dimension	Packaging	Carton Size	G.W/kg
PP	84*78*207	30PCS/CTN	460*310*470	12.65

•5100LCD



•5100LED



•5200



•5310



•5600



•5700

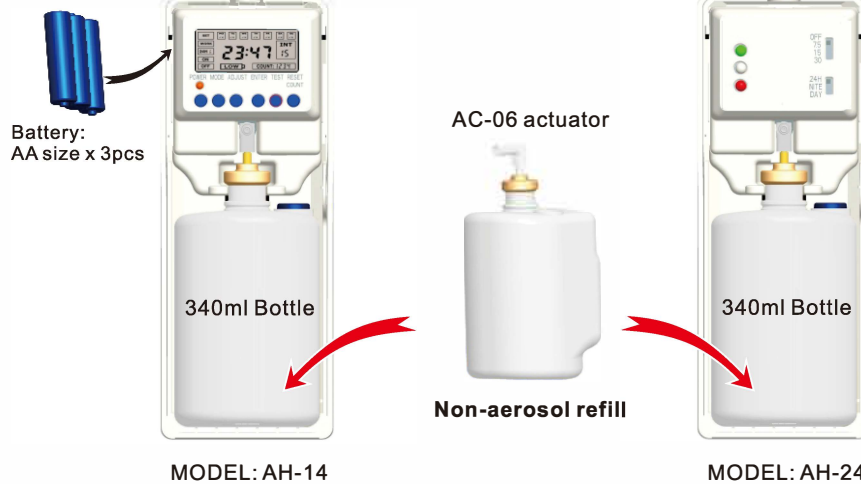

Pump Dispenser



H: 247mm

5300 Series of Liquid Pump Spray Dispenser

- For use with non-aerosol refill
- Interchangeable action head design. Easy installation and quick changes
- Two versions: Programmable LCD AH-14 and Economy LED AH-24
- Operates with 3xAA alkaline batteries (LR 6)
- Compatible with 360ml refillable bottle
- Pump option: crimping pump PM-120C dosage at 0.12ml and actuator AC-06
- Eco friendly recyclable PP material. Chemical-resistant
- Color options: white, and customized colors

Material	Dimension	Packaging	Carton Size	G.W/kg
PP	90*77*247	30PCS/CTN	450*320*560	15.1

•5300



•5400

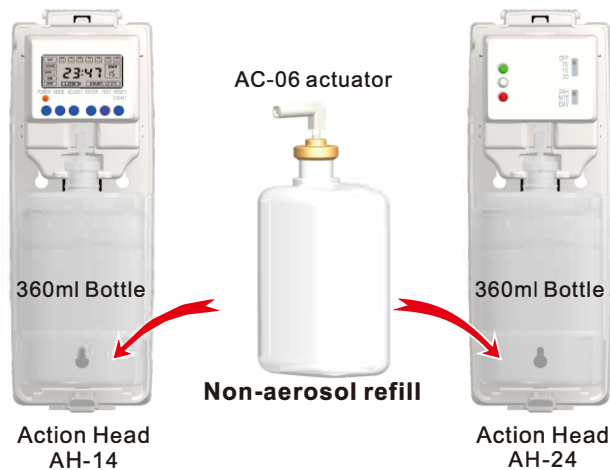

Action Head For Pump Dispenser



MODEL:AH-14



MODEL:AH-24

BIG SPACE FRAGRANCE DIFFUSER



Big Space Fragrance Diffuser



H: 255mm

Big Space Fragrance Diffuser

6000

- Supporting SMART APP operation
- Venturi system, specifically for fragrance oil
- Programmable LCD settings
- Power-off protection, settings can be kept under sudden power-off situation
- Working with 12V DC power supply
- Refill capacity: 350ml, refillable bottle
- Dosage: 1.5-2.0g/hour, covering up to 500m³ area
- Optional spraying solution: front, top or with tube connection
- Security key and lock
- Polypropylene material, eco-friendly and chemical-resistant
- Color options: white and customized colors



350ml

VT-04
Dosage: 1.5-2.0g/h

Material	Dimension	Packaging	Carton Size	G.W/kg
PP	274*83*255	12PCS/CTN	340*370*270	6.22

Patent



Disposable Venturi Fragrance Diffuser

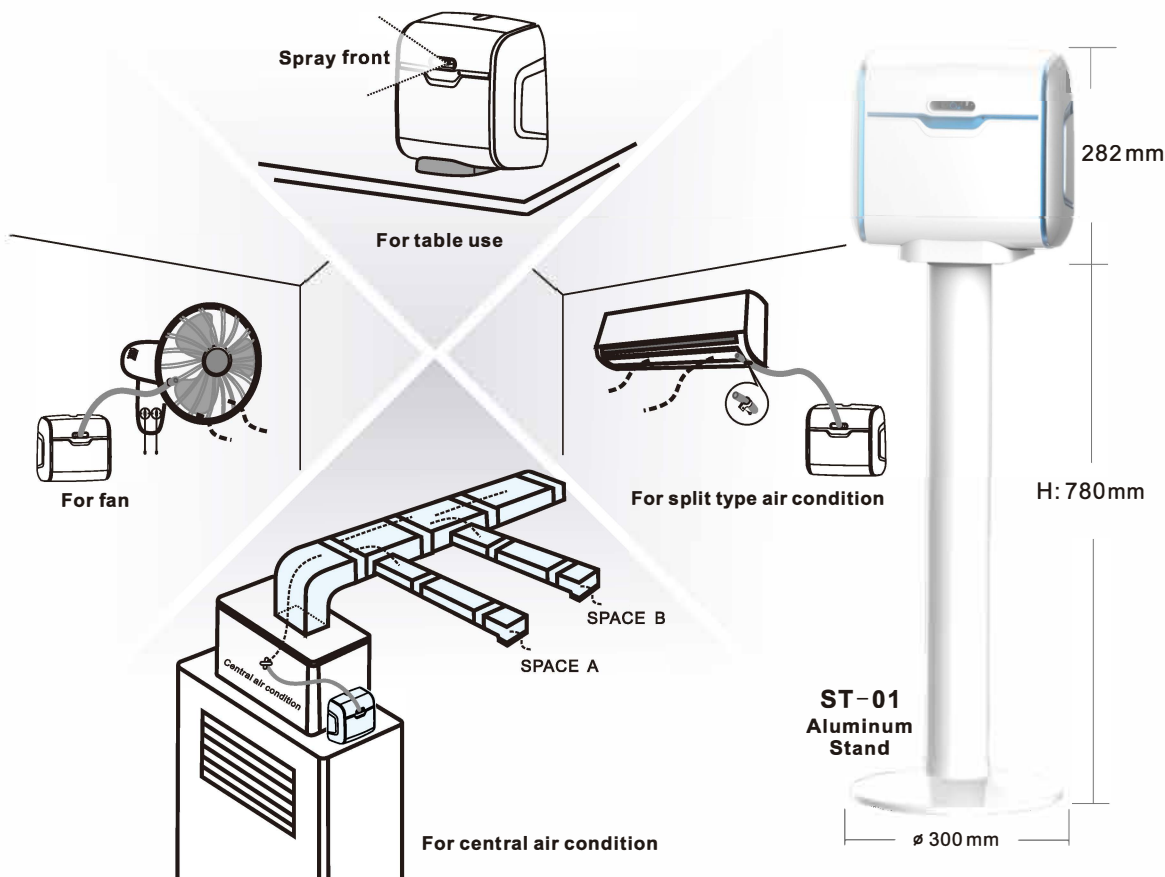

Big Space Fragrance Diffuser



H: 244mm

6100

Big Space Fragrance Diffuser

6100

- Supporting SMART APP operation
- Venturi system, specifically for fragrance oil
- Slim design, front cover opening from the side
- Programmable LCD settings
- Power-off protection, settings can be kept under sudden power-off situation
- Working with 12V DC power supply
- Refill capacity: 350ml, refillable bottle
- Dosage: 1.5-2.0g/hour, covering up to 500m³ area
- Security key and lock
- Polypropylene material, eco-friendly and chemical-resistant
- Color options: white and customized colors

Material	Dimension	Packaging	Carton Size	G.W/kg
PP	156*111*244	12PCS/CTN	490*480*270	6.22



VT-04

Dosage: 1.5-2.0g/h



H: 172mm

Mini Fragrance Diffuser

6210

- Venturi system, specifically for fragrance oil
- Noiseless structure
- Compact design, front cover opening from the side.
- UV décor board available for customized printing
- Optional bases: programmable LCD and economy LED
- Working with 2pcs D size alkaline batteries (LR20) or 6V DC power supply
- Refill capacity: 100ml, refillable bottle
- Dosage: 1.6-3.2g/hour, covering up to 500m³ area
- Security key and lock
- Polypropylene material, eco-friendly and chemical-resistant
- Color options: white and customized colors

Material	Dimension	Packaging	Carton Size	G.W/kg
PP	140*54*172	24PCS/CTN	300*360*360	8.5

Patent

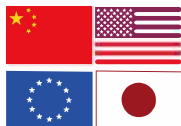

Disposable Venturi
Fragrance Diffuser



UV décor board



VT-05

Dosage: 1.6-3.2g/h



Battery:
D-Size X 2pcs

LCD



LED

Aroma Gellan Gum

Since its early establishment, FANER has been primarily focused on the core business of Gellan Gum. Over the years, we have gathered extensive experience in various aspects, including but not limited to formula creation, structure design, odor & reliability testing, maintaining competitive pricing and meanwhile ensuring stringent quality control. Our accumulated expertise makes us capable of developing customized scented Gellan Gum products.

1. Formula creation & Structure design

FANER has gained invaluable expertise working with some of the world's largest daily necessities supply companies and supplying to various nations. Years of practical experience, keen insight into market trends, and technical know-how are some of our most significant advantages. Based on these we are able to create customized formula and design specific structure to meet your need.



2. Odor & reliability testing

We have designed and conducted in-house testing process, covering chemical analysis, site odor check, shipping emulation, etc. to eliminate potential risks, waste in time and costs. Along with 3rd party testing and analysis, to ensure reliability of each unit gellan gum product.

3. Competitive price

Automation projects including injection, printing, assembly and packaging equipment have launched since 2014, and have been upgrading from time to time, to enhance production capacity and optimizing production ability. These strong bases lead us able to propose competitive prices.

4. High capacity

High production capacity up to 100,000pcs per day.

5. Quality control

FANER as a qualified supplier, has been running strict inspections throughout the whole production process including incoming material, storage warehouse, production, packaging and shipping. Our standard facility, validated equipment, well-trained employees and complete SOP also builds a strong foundation in quality control. Making sure each gellan gum product is well qualified.

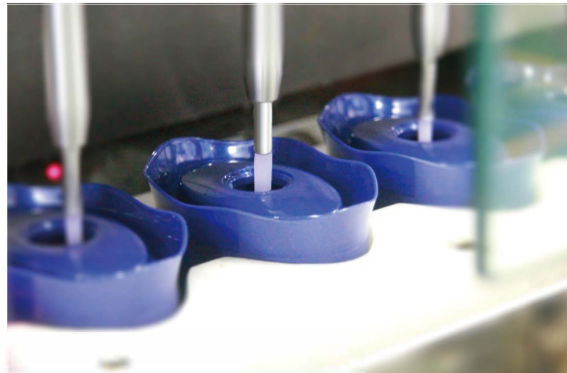

Air Freshener

Aroma Gellan Gum Air Freshener

- Elegant design, 180g
- Adjustable intensity, simply by lifting cover up or down
- Optional fragrances: Starry sky, Rose, Lemon, Lavender, Green tea and customized options
- Long-lasting scent up to 1 month
- Available for ODM and OEM business
- Efficient automated production, daily capacity up to 100,000pcs



Fragrance Liquid Can Air Freshener

- Universal size of 100 ml
- Adjustable intensity, working with or without paper wick
- Available for Fan Dispenser series
- Optional fragrances: Lavender, Rose, Lemon, Ocean and customized options
- Long-lasting scent up to 1 month



Lavender
FC-LA9100

Rose
FC-RO9100

Lemon
FC-LE9100

Ocean
FC-OC9100

Fragrance Wooden Wick Air Freshener

- Compact size
- Available for Faner Dispenser series
- Optional fragrances: Lavender, Rose, Lemon and customized options
- Long-lasting scent up to 1/2 month



Car Air Freshener

- Mini size
- Special design of simple click-on
- Available for various occasions: Car, vent, air conditioner, fan, etc.
- Customizable fragrances
- Long-lasting scent up to 1/2 month
- Available for ODM and OEM business
- Efficient automated production



Skin Care Product

Skin Care Refills

Optional refills including:

Foam Soap
Lotion Soap
Alcohol Foam
Alcohol Sanitizer

- Special formula creating both pleasant scent and excellent cleaning performance
- Optional refill volume: 500ml, 600ml, 800ml, 1000ml, 1200ml and customizable volume
- Hygienically sealed
- Space saving
- Verified quality
- Customizable refill fragrance and color
- Available for ODM and OEM business

1. Foam Soap Refills SKU# 19082804

- Enriched foaming performance
- Up to 2500 times of dosages with 1000ml volume

2. Lotion Soap Refills SKU# 19082803

- Special antibacterial formula for good cleaning performance
- Up to 1000 times of dosages with 1000ml volume

3. Alcohol Foam Refills SKU# 19090405A

- Water-free foam sanitizer
- Enriched foaming performance
- Up to 2500 times of dosages with 1000ml volume

4. Alcohol Sanitizer Refills SKU# 19082801A

- Fragrance-free and Water-free alcohol sanitizer
- Up to 1000 times of dosages with 1000ml volume



SANITARY BIN



Comfort Sanitary Bin

TB-01

- 25 liters large capacity
- Slim design for saving space
- A fitted lid to prevent odor spreading
- Easy to maintain and clean
- Simple and reliable

Material	Dimension	Packaging	Carton Size	G.W/kg
PP	346*170*660	6PCS/CTN	550*720*670	12.5



Sanitary Disposal Products

TB-02A TB-02M

- 25 Liters Large Capacity
- Hand Free Automatic Sensor option/ Manual hand-lift option
- Body made with PP material. Offering chemical and stain resistance and durability
- Concealed handle for easy lifting
- Automatic model operates with 4xC batteries. Long battery life

Material	Dimension	Packaging	Carton Size	G.W/kg
PP	152*469*600	6PCS/CTN	310*940*610	12.1





Mounting Plate

BP-01

- Used for dispensers to be mounted on the wall, and to be removed easily and quickly
- Installed with screws or double sided tape
- Material: ABS



Mounting Plate

BP-02

- Used for dispensers to be mounted on the wall, and to be removed easily and quickly
- Installed with screws or double sided tape
- Material: ABS



Glue Mounting Plate

BP-03

- Used for dispensers to be mounted on the wall, and to be removed easily and quickly
- Supports more than 50kg
- Installed with glue
- Material: stainless steel



Two-Sided Tray

TP-01

- Suitable for soap dispensers or hand disinfectant dispensers
- Two-sided design to work on both sides. Flexible for installation
- Installed with screws
- Material: ABS



Long Tray

TP-02

- Suitable for soap dispensers or hand disinfectant dispensers
- Installed on wall or with the stand ST-01, ST-05 and ST-06
- Material: Melamine



Round Tray

TP-03

- Suitable for disinfectant dispenser 7400, 7420A and 7420M
- Table top use, or with the stand ST-01, ST-05 and ST-06
- Material: Melamine



Aluminium Stand

ST-01

- Dimension : Ø300mm*Ø88.5mm*H720mm
- Weight : 2.2KG
- White painting finishing
- Innovative solution to easy install and release
- Material: Aluminum and ABS



Aluminium Stand

ST-05

- Dimension : Ø400mm*Ø88.5mm*H720mm
- Weight : 3.8KG
- White painting finishing
- Innovative solution to easy install and release
- Material: Aluminum and ABS



Aluminium Stand

ST-06

- Dimension : Ø400mm*Ø88.5mm*H720mm
- Weight : 3.6KG
- White painting finishing
- Innovative solution to easy install and release
- Material: PVC and ABS

Accessories

Actuators



MODEL:AC-01
Aerosol Actuator
Stem: 2.8~3.0mm



MODEL:AC-02
Aerosol Actuator
Stem: 2.8~3.0mm



MODEL:AC-03
Aerosol Actuator
Stem: 2.8mm



MODEL:AC-04
Aerosol Actuator
Stem: 2.8mm



MODEL:AC-05
Aerosol Actuator
Stem: 2.8mm



MODEL:AC-06
Pump Actuator
Stem: 3.0mm



MODEL:AC-08
Aerosol Actuator
Stem: 2.8mm



MODEL:AC-09
Aerosol Actuator
Stem: 2.8mm



MODEL:AC-12
Pump Actuator
Stem: 6.0mm



MODEL:AC-13
Pump Actuator
Stem: 3.9mm



MODEL:AC-14
Pump Actuator
Stem: 6.0mm

Valve & Pump



MODEL:AF-35
Metered Valve
Ø1 inch, 40~50mcl
Stem: 2.8mm, metal/plastic

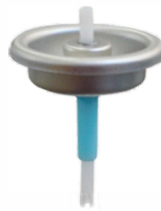

MODEL:AF-75
Metered Valve
Ø1 inch, 75~85mcl
Stem: 2.8mm, metal/plastic



MODEL:AF-100
Metered Valve
Ø1 inch, 100~110mcl
Stem: 2.8mm, metal/plastic



MODEL:TF-75
Metered Valve
Ø20 mm, 75~85mcl
Stem: 2.8mm



MODEL:TF-100
Metered Valve
Ø20 mm, 100~110mcl
Stem: 2.8mm



MODEL:PM-100C
Liquid Pump
Ø20 mm Stem 3.9mm
Dosage: 0.10ml



MODEL:PM-120C
Liquid Pump
Ø20 mm Stem 3mm
Dosage: 0.12ml



MODEL:PM-120S
Liquid Pump
Ø20 mm Stem 3mm
Dosage: 0.12ml



MODEL:PM-230S
Liquid Pump
Ø20 mm Stem 9.5mm
Dosage: 0.23ml

Accessories

FOAM PUMP KIT

		2020 NEW	2020 NEW	2022 NEW	2022 NEW		2022 NEW	
FPK-01	FPK-02	FPK-04N	FPK-05	FPK-15	FPK-16	FPK-30	FPK-30N	FPK-43
								
0.4ml	0.4ml	Durable 0.4ml	Durable 0.4ml	Durable 0.6ml	Durable 0.6ml	0.4ml	Durable 0.4ml	0.75ml

LOTION/GEL PUMP KIT

							2022 NEW
LPK-08	LPK-10	LPK-11	LPK-12	LPK-13	LPK-14	LPK-15	
							
0.5ml	0.5ml	0.5ml	1.0ml	1.0ml	1.0ml	Durable 0.6ml	

SPRAY PUMP KIT

SPK-08	SPK-10	SPK-11	SPK-12	SPK-13	SPK-14
					
0.5ml	0.5ml	0.5ml	1.0ml	1.0ml	1.0ml

PERMANENT LOTION PUMP

SPK-03B Gel	SPK-07 Gel	SPK-07B Gel	TPV-01	TPV-02	TPV-03
					
0.2ml	1ml	1ml			

TUBING PUMP VALVE

PERMANENT SPRAY PUMP

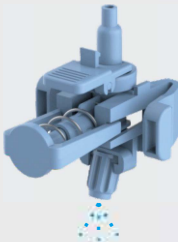
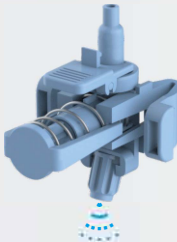
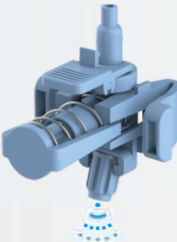
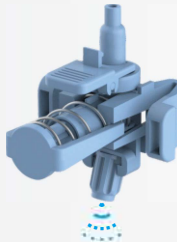
SPK-03 Spray	SPK-06C Spray	SPK-06 Spray	SPK-06N Spray
			
0.2ml	0.5ml	1ml	1ml

Accessories

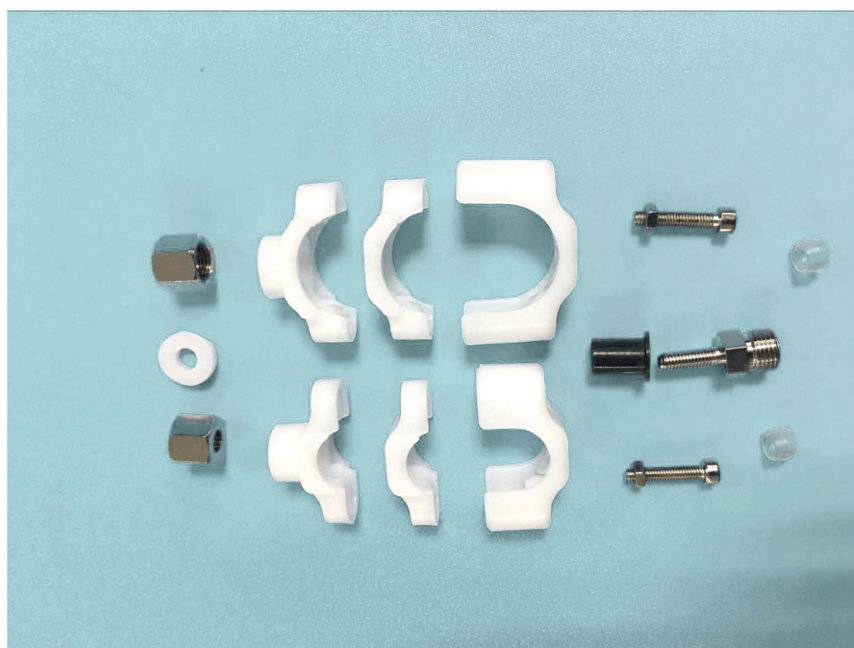

Installation Kit of Sanitizer Dispenser

SAN-01

- Two different seals to work with different specifications of pipes, range from 12-13mm and 17-18mm
- All parts of the kit are optional, you can choose some parts according to your way of installation
- Connecting with diameter 6mm tubing

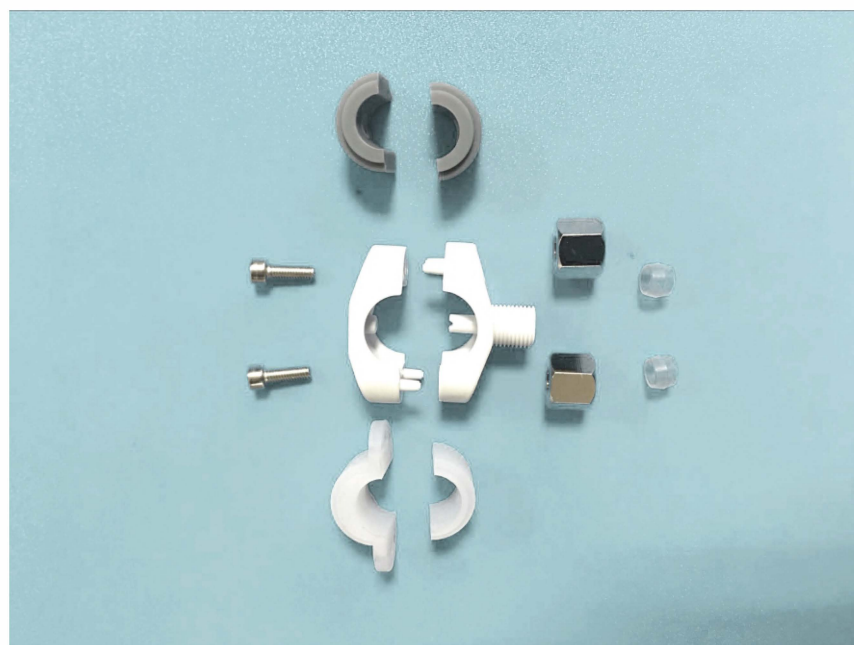

Installation Kit of Sanitizer Dispenser

SAN-02

- Three different clamps to work with different specifications of pipes, range from diameter 13-17mm, 17-25mm or bigger than 25mm
- All parts of the kit are optional. Choose your parts according to your way of installation
- Connecting with diameter 6mm tubing